

REDUCE

REUSE

COMPOST

RECYCLE

Contact us

We are keen to hear from local people and other interested individuals or organisations and would positively welcome comments on this document.

Comments about this annual report may be submitted to:

The Clerk

Western Riverside Waste Authority
Smugglers Way
Wandsworth
London SW18 1JS

Tel: (020) 8871 2788

You can contact WRWA's Offices on
020 8871 2788 or via email at info@wrwa.gov.uk

This report and other useful information about WRWA is available on our website www.wrwa.gov.uk

WESTERN RIVERSIDE WASTE AUTHORITY 2019/20



**END
OF THE
LINE FOR
WASTE**

Waste reduction, reuse,
recycling and energy
recovery in your area
OUR WAY FORWARD

Designed and produced by
Wandsworth Design & Print.
wdp@wandsworth.gov.uk
WA.37 (9.20)







Contents

Foreword by the Chairman

- Section 1** Introduction to WRWA
 - Section 2** WRWA's waste management policy
 - Section 3** What WRWA does with your waste
 - Section 4** Prevention and reuse
 - Section 5** Recycling
 - Section 6** Recovery
 - Section 7** Looking back – 2014/15 to 2019/20 review
 - Section 8** Looking forward – a future for waste
 - Section 9** Sustainability statement
 - Section 10** Financial statement
 - Section 11** How can the public help?
 - Section 12** Glossary
- Contact us**

Western Riverside Waste Authority (WRWA) is one of four Statutory Joint Waste Disposal Authorities in London which are charged by Parliament with managing the waste collected by their respective constituent councils. In the case of WRWA, these are the London Boroughs of Hammersmith & Fulham, Lambeth, Wandsworth and the Royal Borough of Kensington and Chelsea.

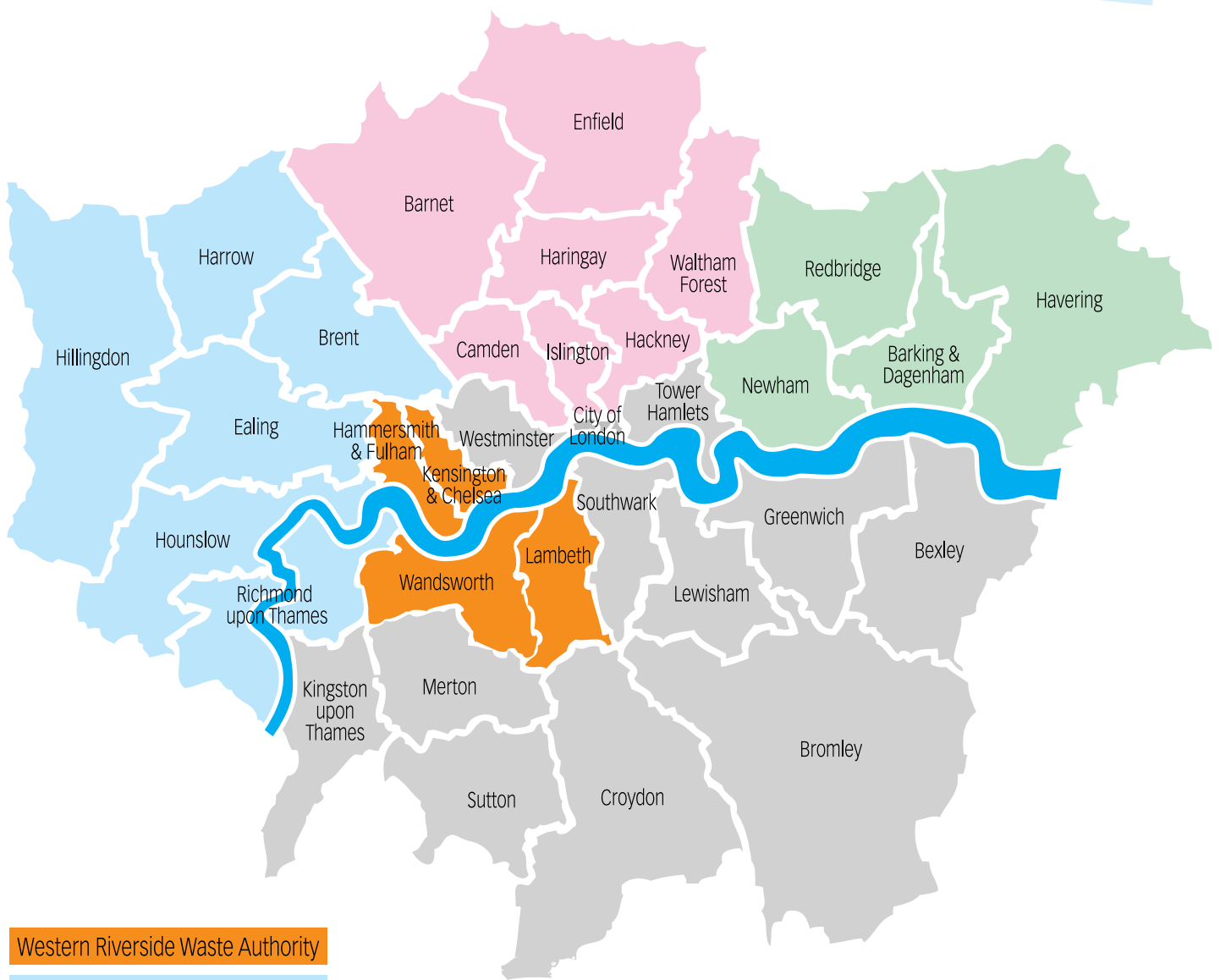

- Western Riverside Waste Authority
- West London Waste Authority
- North London Waste Authority
- East London Waste Authority

Foreword by the Chairman



A relatively quiet year for the Authority ended in a manner which of course no-one could have predicted a year ago, with the arrival of the Coronavirus pandemic in March and the introduction of lockdown restrictions. Prior to this, in conjunction with our four constituent boroughs, we had continued our focus on waste minimisation and improving our reuse and recycling performance with our two communications campaigns - "End of the Line for Waste" and "What happens to your Recycling". These used a combination of public events, videos, social media and local adverts to target specific waste and recycling streams and provide reassurance to residents that the recyclable material they leave out for collection is being properly recycled.

Our Education Team remained busy, both with outreach work in schools and hosting visits to the Education Centre and MRF. These continued to be extremely popular with local schools, colleges and residents as

well, with the team also running Saturday morning and ad hoc evening tours for adults. But, sadly, since mid-March we have had to suspend our schools and adult tours as well as all outreach activities, although the Team have remained busy and creative, producing Home Learning Resource tools for schools and working on the production of a remote education programme, including virtual tours of the operations at Smugglers Way and the MRF.

However, our primary responsibility – to receive, treat, transport and dispose of recycling and waste collected by our boroughs from their residents – remains unchanged and is a key public service. I am delighted to report that our operations have been able to continue with virtually no disruption during the past few challenging and extraordinary months. Although our Household Waste and Recycling Centre was closed for a temporary period during lockdown our operational contractor, Cory Riverside Energy, and ALS Managed Services who supply the workforce for the MRF, have continued to process the waste and recycling generated within the Authority's area efficiently and remarkably well, with limited impact on our essential services. Our office-based staff have also carried on business as usual whilst working effectively from home; co-ordinating our activities, liaising and collaborating closely with our borough collection

colleagues and other waste authorities and providing information and regular updates to residents.

My constituent council colleagues and I wish to convey our sincere thanks and congratulations on the remarkable efforts of all concerned in helping to keep our waste management services up and running as normal.

A handwritten signature in black ink, appearing to read 'J Husband', with a horizontal line underneath.

Councillor James Husband
WRWA Chairman

Introduction to WRWA

Western Riverside Waste Authority was established in 1986 as an autonomous statutory local government body to undertake the waste disposal functions prescribed by the Local Government Act 1985 and the Waste Regulations and Disposal (Authorities) Order 1985.

WRWA is responsible for managing the waste collected in the London Boroughs of Hammersmith & Fulham, Lambeth, Wandsworth and the Royal Borough of Kensington and Chelsea.

The boroughs have a combined population of approximately 994,000 living in 407,000 households. WRWA receives approximately 373,000 tonnes of recyclables and waste from the councils and their residents. In addition Cory Riverside Energy, our contractor, handles 171,000 tonnes of local trade and commercial waste and recycling through WRWA's facilities.

Photo: webaviation.co.uk

WRWA members

WRWA comprises eight Members who are appointed by its four constituent councils – each council appoints two elected Councillors annually to serve on the Authority. The Members meet regularly through the year (on at least four occasions), have overall responsibility for the policy and management of WRWA and are required (when representing the Authority) to act in the interests of WRWA as the Waste Disposal Authority for the combined area. The role of Members is described below.

Collectively, Members are the ultimate policy-makers and those responsible for the strategic and corporate functions of WRWA.

They participate in the governance and management of WRWA. They represent WRWA on other bodies.

They have a duty to maintain the highest standards of conduct and ethics and follow a Code of Conduct.

They work with the constituent councils.

They work with and influence regional and national partners such as the Mayor of London and the Environment Agency.

They approve responses to consultation documents.

Members 2020/21

Hammersmith & Fulham Council
Cllr Wesley Harcourt
Cllr David Morton

Kensington and Chelsea Council
Cllr James Husband (Chairman)
Cllr Matthew Palmer

Lambeth Council
Cllr Jackie Meldrum
Cllr Claire Holland

Wandsworth Council
Cllr Mrs Steffie Sutters
(Deputy Chairman)
Cllr Guy Senior

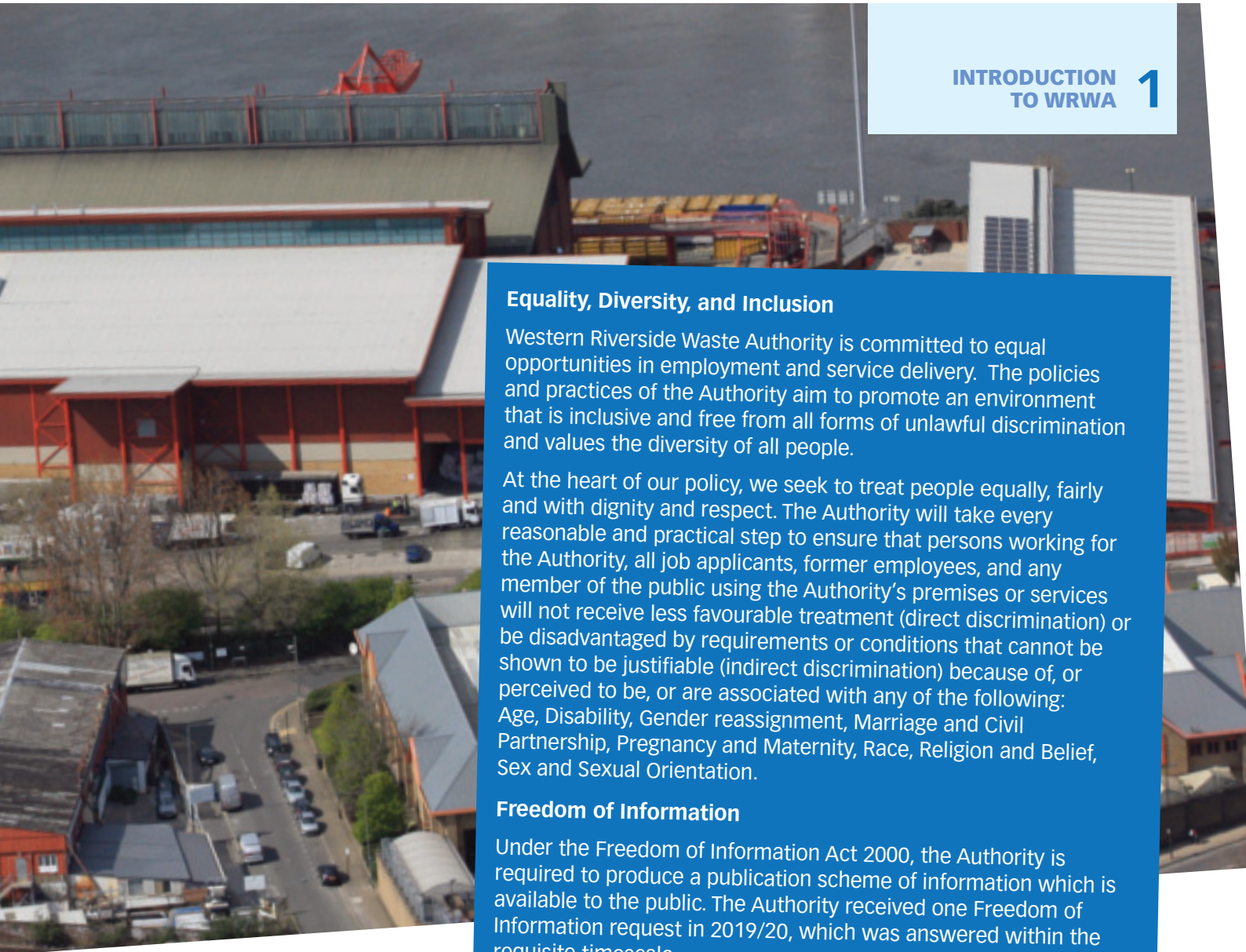

Equality, Diversity, and Inclusion

Western Riverside Waste Authority is committed to equal opportunities in employment and service delivery. The policies and practices of the Authority aim to promote an environment that is inclusive and free from all forms of unlawful discrimination and values the diversity of all people.

At the heart of our policy, we seek to treat people equally, fairly and with dignity and respect. The Authority will take every reasonable and practical step to ensure that persons working for the Authority, all job applicants, former employees, and any member of the public using the Authority's premises or services will not receive less favourable treatment (direct discrimination) or be disadvantaged by requirements or conditions that cannot be shown to be justifiable (indirect discrimination) because of, or perceived to be, or are associated with any of the following: Age, Disability, Gender reassignment, Marriage and Civil Partnership, Pregnancy and Maternity, Race, Religion and Belief, Sex and Sexual Orientation.

Freedom of Information

Under the Freedom of Information Act 2000, the Authority is required to produce a publication scheme of information which is available to the public. The Authority received one Freedom of Information request in 2019/20, which was answered within the requisite timescale.

Complaints

The Annual Report is used to provide statistical information on complaints received during the year under review. In 2019/2020 the Authority received eight complaints, all of which were responded to and, if necessary, actioned. These complaints were varied and related to a number of areas, including late night noise, lack of physical assistance by HWRC staff, misinformation provided by HWRC staff and a resident being denied access to the Centre.

WRWA meetings

Authority meetings are the main decision-making forum for WRWA matters. At these meetings, the Authority sets its overall corporate direction, policy framework and financial limits, within which all of WRWA's operations and policies are carried out.

Authority meetings are generally held four times a year. They are open to the public and attendance is encouraged, unless exempt or confidential matters are being discussed.

Further details about meetings and the dates of future meetings are available on our website, www.wrwa.gov.uk, or by contacting the Administration Office on **020 8871 2788**.



The organisational structure of WRWA

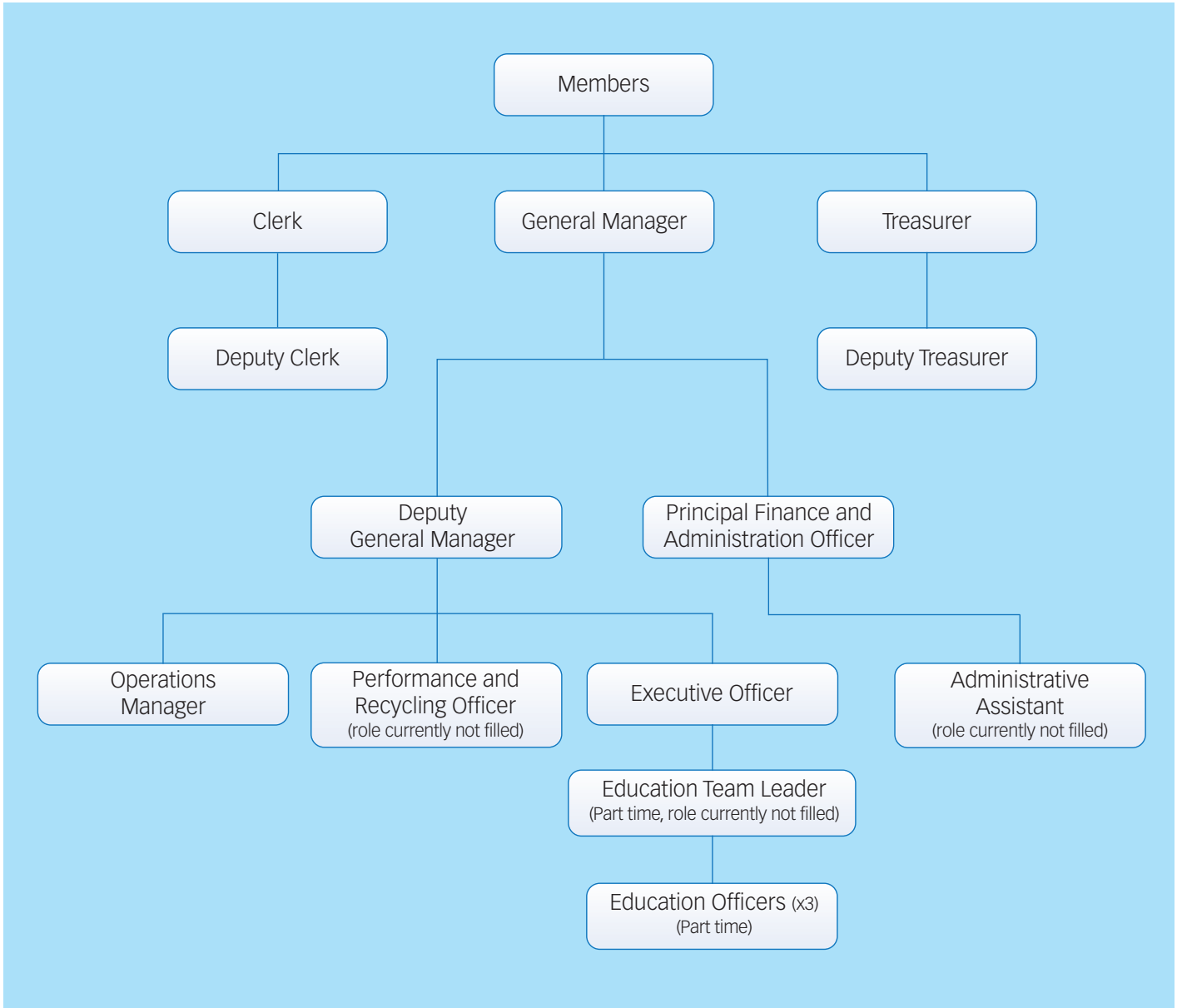

WRWA officers and staff

The Authority is based at Western Riverside Transfer Station, Smugglers Way, Wandsworth, London SW18 1JS.

Nearly 95% of the Authority's revenue budget is spent on contract payments. There are 9.3 full time equivalent posts including the General Manager employed by WRWA. Some financial and administrative support is also provided to the General Manager by Wandsworth Council and, in addition, each of the four constituent councils provides a designated Technical Officer to liaise with the Authority and inform it of the views of the constituent councils. Technical Officers attend eight officer liaison meetings a year in addition to the four Authority meetings

WRWA's Waste Management Policy

Western Riverside Waste Authority and its constituent councils are responsible for the collection, recycling, composting and treatment of some 373,000 tonnes per annum of household and commercial waste generated within their boundaries.

The Authority has pursued a progressive and innovative approach to waste management that is waste minimisation and recycling-led, whilst utilising the River Thames for bulk transportation. Working in co-operation with each other and the private and not-for-profit sectors, the Authority and its constituent councils have focussed on the needs of residents to provide a sustainable waste management service that should set a precedent for future waste management developments in London.

At the heart of the Authority's Policy is a co-ordinated approach to investment which means not simply an investment in infrastructure, but also an investment in people. Ultimately, it

is the people living and working in the WRWA area who are the key to delivering the Authority's aims and objectives.

The Authority has established integrated waste management systems which ensure the Best Practicable Environmental Option is pursued for each particular waste stream and that these:

- embrace the concepts of waste prevention;
- seek to achieve a continued reduction in the amount of waste produced;
- increase the amount of waste that is re-used;
- recycle, compost or recover energy from the waste that is collected;
- minimise the environmental impact of transporting the waste;
- encourage the creation of new, meaningful, job opportunities;
- minimise disruption to others; and
- reduce the costs of operations to provide the best possible deal for Council Tax payers.





The Authority has pursued a **progressive and innovative approach** to waste management that is **waste minimisation** and **recycling-led**, whilst utilising the River Thames for bulk transportation.



What WRWA does with your waste

In May 2002 WRWA entered into a long-term contract, known as the Waste Management Services Agreement (WMSA), with Cory Environmental Limited (now trading as Cory Riverside Energy). This contract is helping WRWA to realise its aim of maximising reuse and recycling and providing a greener future for management of its waste.

The waste management services provided by WRWA and Cory involve waste and recyclable material being delivered to the Authority's two transfer stations, at Smugglers Way in Wandsworth and Cringle Street in Battersea, for either reuse, recycling or treatment.

Western Riverside Transfer Station, near Wandsworth Bridge, can handle over 6,500 tonnes of waste and recyclables per week. WRWA's second transfer station, Cringle Dock, is located next to Battersea Power Station and can handle over 6,000 tonnes of waste and recyclables every week.

Both transfer stations use state-of-the-art technology in waste containerisation and operate efficiently and to the highest environmental standards.

Cory takes advantage of spare capacity at the transfer stations for the receipt of local trade and commercial waste.

WRWA currently provides an integral Household Waste and Recycling Centre (previously known as a Civic Amenity Site) at its Smugglers Way transfer station and Lambeth Council also provides its own, additional, Reuse and Recycling Centre at Vale Street, West Norwood.

WRWA receives co-mingled and separated recyclables at its transfer stations and a Materials Recycling Facility (MRF) was constructed at Smugglers Way in 2010/11, so that most of the separation and baling process is now carried out on site, and the baled materials are then transported on to their various reprocessing facilities in the UK or Europe.

Green Waste collected by the constituent councils and at WRWA's Household Waste and Recycling Centre is bulked at the transfer stations for onward transportation to a number of centralised composting facilities within, or just outside, the London area.

The waste that cannot be reused or recycled is compacted into containers before being loaded onto barges for their onward river journey. Historically, this was to Cory's landfill site located on the Thames Estuary at Mucking, Essex, but since the completion of Riverside Resource Recovery Limited's (RRRL) Energy from Waste Facility at Belvedere, in the London Borough of Bexley, the waste has been used for energy recovery. The Authority is now sending "zero waste" direct to landfill and is generating enough electricity to power over 100,000 homes.

Collaborative negotiation between the Authority and Cory Riverside Energy led, in 2017, to a successful restructuring of the Belvedere Energy from Waste (EfW) Facility's long term borrowing which will generate significant financial savings for the Authority as a consequence. The Facility will, for decades to come, ensure a secure and environmentally sound treatment method for the waste which cannot be reused or recycled.

In November 2017 Cory published plans to build an integrated, low-carbon energy park at its site in Belvedere, South East London. This would complement Cory's existing Riverside EfW Facility and comprise a range of technologies, including waste energy recovery, anaerobic digestion, solar panels, and battery storage.





The Government's Waste Hierarchy

Prevention



Preparing for Reuse



Recycling



Other Recovery



Disposal

It would also enable more of London's residual "black bag" waste to be converted into green electricity, particularly during times of peak usage, and produce cheap heat for export to nearby homes and businesses. In addition, it would continue to convert the residual ash left over at the end of the process into construction materials useful for building London's homes and roads.

The application was accepted for examination by the Planning Inspectorate in December 2018 and a decision is expected in April 2020. If the planning process is successful, construction is targeted to begin in 2021, with the Energy Park to be fully operational by 2024.

Year-on-year increases in the rate of landfill tax mean that the **landfilling** of waste has become an **uneconomic proposition** as well as one which is found at the bottom of the waste hierarchy in terms of its **impact on the environment.**

Prevention and reuse

Recycle Western Riverside

Recycle Western Riverside (RWR) is a communications and outreach campaign which encourages residents to Reduce, Reuse and Recycle their rubbish (the three R's).

The campaign has been running since 2002 and is funded by WRWA. The RWR campaign consists of an education function carried out by four Education Officers and a communications programme which is directly managed by Authority staff.

The four Education Officers are directly employed by the Authority on a part time/term time only basis. These Officers have the responsibility for using the Visitors Education Centre to host and conduct educational talks and tours for schools, colleges, community groups, residents' associations and other interested parties based in the Authority's area, with particular emphasis on the three R's and the importance of recycling correctly. Their responsibilities also include the promotion of these education services and outreach work in schools.

The Education Team work with both schools and local residents to promote the three 'R's and they host regular tours of the MRF



Visitors Education Centre at Smugglers Way.

The Authority's team of education officers run tours of the Smugglers Way site for visiting primary and secondary schools and deliver a range of outreach activities in school for all age groups, from Nursery upwards. The aim of the programme is to teach children the 3R's of waste – Reduce, Reuse and Recycle – and encourage them to put them into practice in their daily lives, contributing to a better environment for everyone. The programme uses fun and engaging stories, craft activities, games and hands-on sorting of waste to get the message across.

In 2019/20 the Education Team added a new food waste workshop to its programme for the year.

Classes and residents groups visiting the Smugglers Way Education Centre see how the recycling materials are processed and how they are separated from each other, using a variety of modern techniques (for more information see Section 5). Talks by the Education Officers and a DVD focus on how we can all contribute to a reduction in waste. Visitors can also see how the residual waste is containerised, loaded onto barges and transported by river. The reuse garden area shows that food can be grown, and food waste composted and reused, using only materials that would otherwise be thrown away. Children visiting the site get a great insight into what happens to the things they throw away and can see for themselves how their recycling is sorted. They even get to make their own piece of recycled paper to take away as a reminder of what they have learnt.

The 'End of the Line for Waste' campaign encourages waste minimisation, targeting plastics, food and garden waste in particular

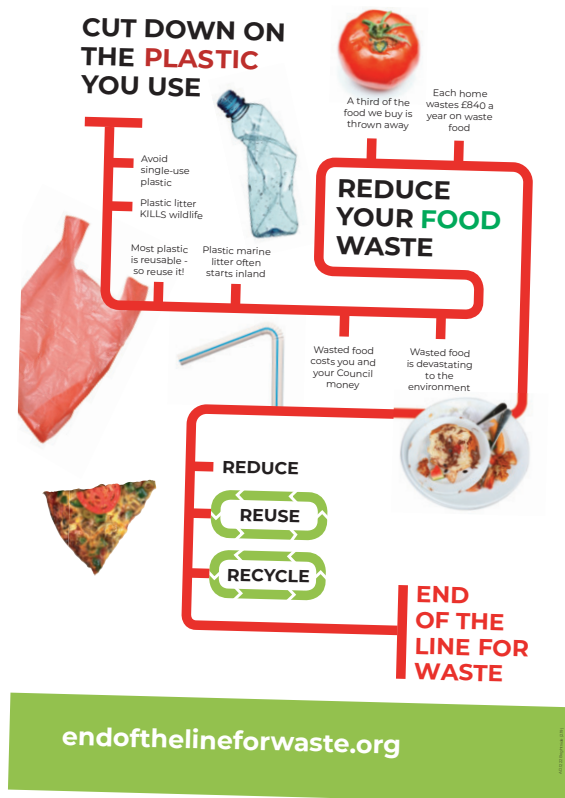

The free workshops and assemblies for schools are a great way to embed the message about the 3R's in the school environment and the team are often asked to take part in eco-weeks to really encourage the whole school to think more about their waste. Activities range from a short assembly to a whole morning of getting-your-hands-dirty, sorting out the school's own waste – with songs, games, crafts and running around in between. All of it is designed to make learning fun and memorable, as well as having a serious message, and is very well received by staff as well as pupils.

The programme is extremely popular with local schools and colleges and, following increased demand from local residents in recent years, the team have also been running Saturday morning and occasional evening tours for adults. The tours take them inside the MRF to view the sorting machinery and find out what really happens to their waste and recycling.

In addition, there are regular monthly weekday evening tours and, in 2019/20

almost 300 local residents have taken part, who it is hoped then go on to become recycling ambassadors for their communities. However, sadly, all tours and outreach activities had to be suspended from the middle of March 2020 due to the Coronavirus outbreak.

The Campaign

RWR manages communication campaigns to promote the 3R's using a variety of methods and media, such as adverts in in-house borough publications, waste collection vehicle livery advertising, local newspaper and borough poster sites advertising. In addition leaflets are sent to residents with their Council Tax bills and information is also disseminated through the use of WRWA and partner websites and social media.

In 2019/20, the Authority made the decision that the RWR communications campaign would consist of two elements: a continuation of our waste minimisation campaign called "End of the Line for Waste" (a campaign focussed on three targeted waste streams – Plastics, Food Waste and Garden Waste) and a "What happens to your Recycling" campaign, aimed at providing reassurance to residents that the recyclable material they leave out for collection is being recycled.

The End of the Line campaign comprised 16 Public Events in July to September 2019 and a further 12 in February and early March 2020, along with adverts in Borough publications, on the sides of buses and the production of 28 videos for social media use. The End of the Line campaign will continue into 2020/21.

The "What happens to your Recycling" campaign included the production of a video, placement of advertising in Borough newspapers, Council Tax bills, on Borough recycling collection vehicles and the use of Social Media.

In addition, during September's Recycle Week, the Authority used WRAP's communications materials on

static and digital roadside bus stop adverts, digital screens in Waitrose and Tesco and 'xAds' across the four WRWA boroughs, the 2019 theme being "Recycling. It's in our hands."

Reuse Project

In line with the waste hierarchy, WRWA and its constituent councils highlighted that they wished to increase the re-use of products and materials received as part of their waste streams.

It was felt that the most effective way of capturing these materials was to work in partnership with experts in reuse, such as London Community Resource Network (LCRN), an umbrella body representing London charities that collect and redistribute reusable items for resale.

Following a successful funding application submitted to the London Waste and Recycling Board (LWARB) for a reuse project in the Authority area, a project was established at Smugglers Way in 2011.

One of the main aims of the reuse project is to help achieve behaviour change within the WRWA area, in line with the established waste minimisation and recycling awareness 'Recycle Western Riverside' campaign. The reuse project helps with changing residents' behaviour by providing a tangible system that will prolong the life of goods and help residents to see the potential value in things they would usually discard.

The project provides affordable items for people who need them and back-to-work opportunities for people who are long-term unemployed. It encourages the reuse of most easily reusable, repairable or recyclable bulky

items which should be in good condition or in a repairable state. These include the items shown in the blue box.

Reusable items are distributed to a wide variety of LCRN members, and it is this access to a large number of varied outlets that is one of the major strengths of the scheme and what sets it apart from others.

The project comprises two elements:

ReWork

One element of the project is a workshop – "ReWork" – at the Smugglers Way transfer station in Wandsworth that is used to refurbish and PAT test reusable large electrical appliances.

Cory has given up space and buildings within the transfer station to create sufficient storage for the reusable goods and items. The access to and refurbishment of these buildings has enabled a safe and fully contained reuse working area to operate away from the main transfer station operations.

Rework is operated by Groundwork London and, with the support of WRWA and Cory, delivers four aims:



4 PREVENTION AND REUSE

- Refurbishing and reusing unwanted domestic items, particularly white goods and furniture.
- providing training and paid work experience to disabled and long term unemployed local people.
- providing high quality affordable large electrical appliances to low income families. There are now eleven full-time members of staff in post and six trainees on waged work experience.
- Diverting approximately 300,000+ tonnes annually of waste from landfill.

Reuse collection service

Each of the constituent councils encourages its residents to consider booking a reuse collection service for items that are in good condition, rather than booking a Council Bulky Waste collection service for disposal of items they no longer need or want. All the constituent councils currently direct their residents to charities such as the British Heart Foundation or Emmaus for furniture and electrical and electronic equipment collections; TRAIID will also collect small to medium-sized waste electrical and electronic equipment, as well as textiles. Additionally, the councils promote the use of online platforms such as Freegle and Gumtree.

In partnership with three other local charities (Royal Trinity Hospice, Wandsworth Oasis and the Salvation Army) the Authority promotes an initiative to divert unwanted goods to local charities. The idea is to highlight to residents who are intending to drop off their recycling and waste in a van the possibility of delivering good quality items such as furniture, white goods, small electrical items, books, household bric-a-brac and clothing to particular charity shops which can accept donations of larger items.

This should result in a reduction in the tonnage of household waste delivered by residents in a van.

The aim is to get these people **work ready** and assist them with finding longer term employment.



The Reuse Project will take:

- **Furniture**
Including bed bases, sofas (with a fire certificate), tables, chairs, cupboards, chests of drawers.
- **Large appliances/white goods**
Including fridges, washing machines, tumble driers, cookers microwaves.
- **Small electrical items**
Including hi fi's, turntables, radios, amplifiers, routers, gaming boxes and accessories, key boards, etc.
- **TV's**
Flat screen only
- **Bicycles**
- **Sports equipment**
- **Bric-a-Brac**
- **Tools**
Including electrical or hand tools.
- **Toys**
For all electrical items, it doesn't matter if they are no longer working.

How to book

For further information visit the London Reuse website www.londonreuse.com or contact the waste and recycling department of your local council or the reuse collection service for your council, as follows:

London Borough of Hammersmith & Fulham and Royal Borough of Kensington and Chelsea

W: www.sbhg.co.uk/furnish
E: furnish.collection@sbhg.co.uk
T: 020 8996 4772

London Borough of Wandsworth

W: www.wandsworth.gov.uk/reusecollection or www.bhf.org.uk/shop/donating-goods.aspx
T: 0808 250 0030

London Borough of Lambeth and London Borough of Wandsworth

W: www.emmaus.org.uk/lambeth
T: 020 8761 4276

Further Training

Following a successful funding application, a "Spare Parts" scheme was established in 2018, through which Rework collects reusable parts from large domestic appliances delivered to the HWRC (that are not themselves in a suitable condition to be reused as whole appliances), sorts and catalogues them and put them up for resale online.

In 2019/20 the Authority, Cory and Groundwork submitted a joint funding application to the VALPAK DTS WEEE Project Fund. The application was to fund an appliance engineer and training for ReWork staff and trainees. The application was successful and Rework recruited an appliance engineer in December 2019, increasing productivity of affordable reused appliances with extra training for their current six trainees, plus the anticipated addition of four further trainees in 2020 following the Coronavirus lockdown.

Recycling

The Authority recycles a whole range of materials at its Household Waste and Recycling Centres and a full list can be found on our website at www.wrwa.gov.uk

The following sections describe what happens to some of the larger recycling streams.

Co-mingled 'recycling sack and bank' scheme

Cory began the construction of an 84,000 tonne per annum Materials Recycling Facility (MRF) at the Authority's Smugglers Way Transfer Station in November 2008. This facility is processing co-mingled recyclate delivered by the Authority's constituent councils from their "Recycling Sack and Bank" schemes.

The MRF

Before construction of the main MRF building itself could start, preparation works were carried out to the river wall and a containment barrier was installed along the eastern boundary of the Household Waste and Recycling site to prevent any slightly polluted water (from the site's historic use as a Gasworks) under the main body of the site from draining into the Thames.

The design and build of the main MRF building and associated civil works were carried out during 2009 and the installation of the bulk of the processing and associated equipment was carried out during 2010. Commissioning commenced in October of that year and the facility was officially opened by Her Royal Highness the Princess Royal in March 2011.

Cory took over the operation of the MRF in April 2011, when the equipment contractor ceased involvement with the commissioning process, and has continued to work through the remaining design and engineering problems that have impacted on the MRF operation.

The MRF has a design capacity of 84,000 tonnes per annum and has been designed to process co-mingled materials, delivered loose or in plastic bags, consisting of a mix of one or more of the following dry recyclables: paper, cardboard, glass bottles and jars, clear and coloured PET plastic (e.g. drink bottles), clear and coloured HDPE plastic (e.g. laundry and washing-up liquid bottles) steel and aluminium cans and polycoat material (e.g. Tetra Pak).

The facility has allowed the Authority to be predominantly self-sufficient in relation to the sorting of collected co-mingled recyclable materials, complying with the proximity principle and reducing vehicle movements associated with this activity. The MRF building incorporates an interactive Education Room providing improved facilities for educational activities in relation to recycling which is of particular benefit to school children and students from colleges in the four boroughs, as well as visitors from the local community and further afield.

The building also benefits from the installation of photovoltaic cells (or solar panels) on its roof and visitors can see a display showing how much electricity they are generating and the carbon emissions saved as a result.

Following two significant fires in 2016, and a lengthy repair period when the MRF only ran at approximately 60%, further fire prevention measures were deployed, including the installation of fire curtains and a deluged water system in addition to the sprinkler



water system. Other improvements carried out alongside the refurbishment works have also resulted in an increase in the efficiency of the MRF.

In recent years the Authority's constituent councils have also taken steps to reduce the contamination rate as far as possible and have largely been successful. One of the key changes has been the introduction of clear recycling sacks to replace the orange recycling sacks used previously. This move enables the collection crews to inspect the contents of the recycling sacks before deciding whether to place them in the recycling or the waste compartment of the collection vehicle, thereby reducing the delivery of non-targeted materials to the MRF.



The Materials Recycling Facility welcomes visitors and, as well as school classes, also encourages adults to book on one of its regular tours

How does the MRF work?

The MRF initially sorts the recyclable materials mechanically based on their specific size and shape properties.

The recycling sacks and bags are loaded onto a conveyor belt and travel through a 'bag splitter' which uses small blades to rip open the bag, releasing the materials.

The loose materials then pass through a sorting cabin where empty recycling sacks and contaminant materials are removed from the conveyor belt.





The rest of the materials travel up onto a set of screens. A screen comprises a set of rotating shafts with steel star-shaped discs spread out over a specific distance and inclined.

On the first screen sheets of cardboard “surf” up and over the screens, whilst the rest of the materials fall through the gaps.

The material that falls through the bottom moves on to the next screen, where the distance between the discs and their speed of rotation is set so that newspapers and pamphlets “surf” over the top and the rest of the material falls through the gaps. This process is then repeated on two further screens to remove mixed papers, plastic bottles, tubs and cans – while the glass and smaller items fall through all the screens.

The material from each screen then goes past an optical sorter that removes any rogue material that has incorrectly “surfed” up a screen (rogue recyclable material is returned to go around the process again). The cardboard and paper products then go through a manual quality control area before being baled or loaded loose into road bulkers.

The cans are removed by magnetic and eddy current separators and the plastic bottles, pots, tubs and trays go through further optical sorters which can sort the material into different chemical types and colours.

The glass goes through a large rotating drum with holes called a ‘trommel’ (that looks like a bit like a washing machine drum) and it separates the smaller items that should not be with the glass.

All the products leave the site by road (as the destinations are many and varied) with newspapers, pamphlets and glass going loose in bulkers and with the other materials being baled and transported by curtain-sided vehicles.

The material can be recycled into many different products – for example, paper is made into new packaging and various paper products, glass bottles and jars are recycled into new bottles, windows, other glass products or used as an aggregate material. In some cases the material is remade into the same product – steel cans become cans once again and some plastic bottles can be made into bottles again, or into other types of plastic container.



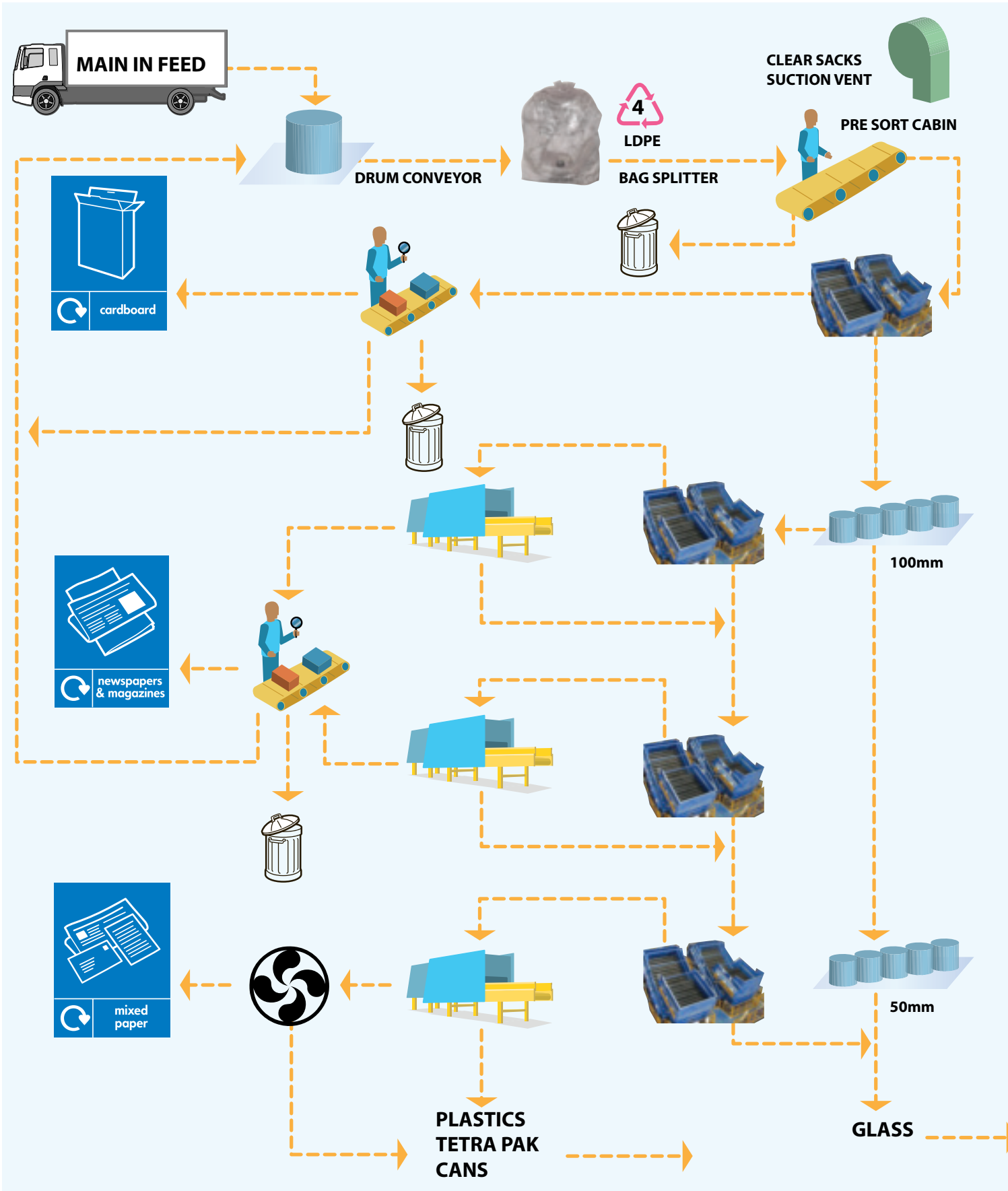

KEY



QUALITY CONTROL



AIR SEPARATOR



BALLISTIC SEPARATOR

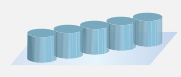

FINES SCREEN

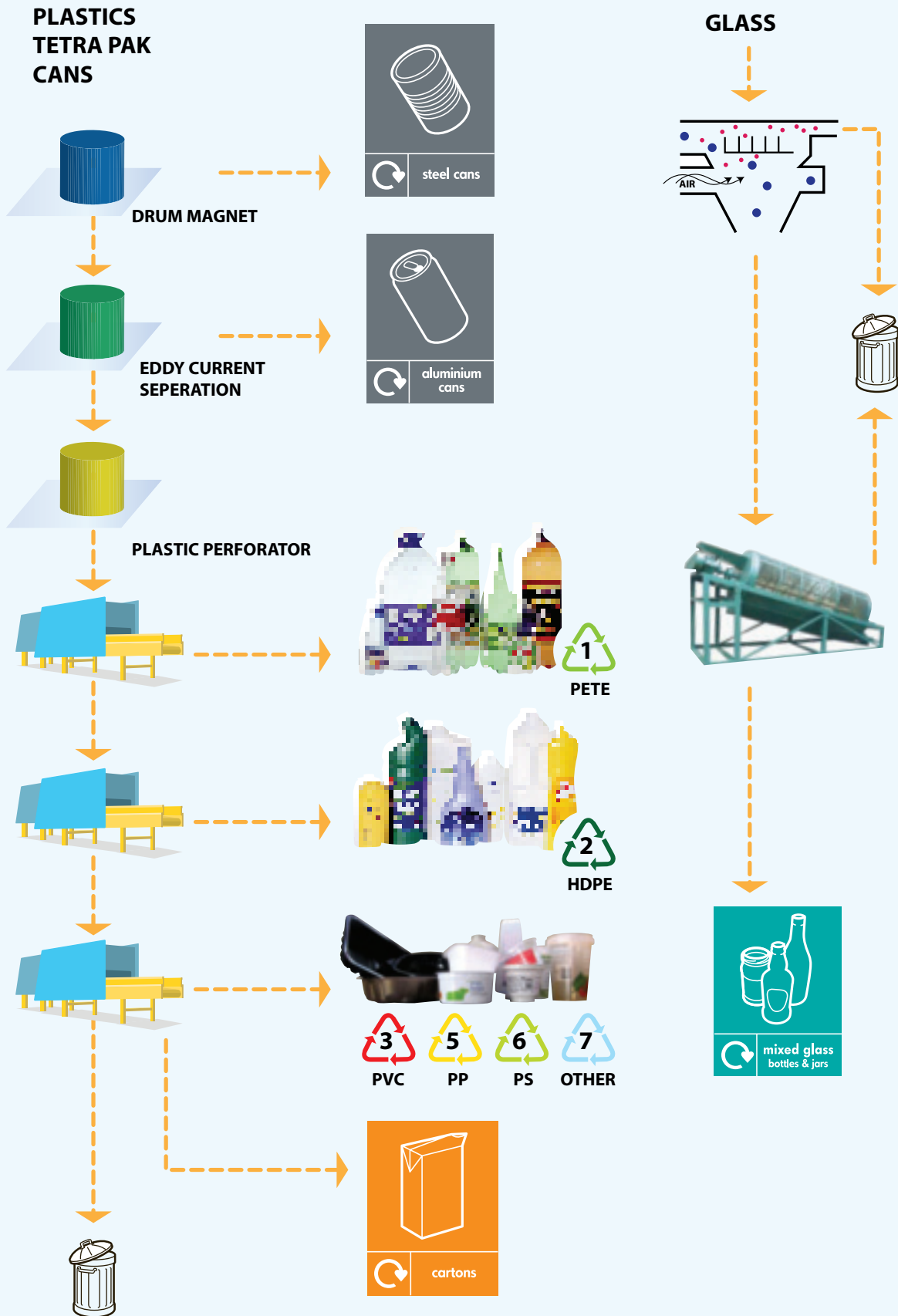

OPTICAL SORTER



TROMMEL
(Separates glass from contaminants)

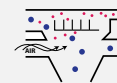

AIR CLASSIFIER
(Removes light material)

Green Waste

Garden Waste delivered by residents to the household waste and recycling centres is sent for composting at an Open Windrow Composting facility. The windrows are regularly turned to improve porosity and oxygen content, mix in or remove moisture, and redistribute cooler and hotter portions of the pile. The temperature of the windrows are measured and logged constantly to determine the optimum time to turn them for quicker compost production.

Detritus Waste

Detritus waste is wet waste collected by mechanical street sweepers and gully cleansing vehicles. Detritus is made up of water, grit, stones, sand, soil, organic waste and litter. This waste is sent off to a specialist re-

processor and 65% of it is currently recycled. The water is cleaned and reused, the grit and stones are used as an aggregate material and the clean litter (mostly cans and plastic) is recycled.

Household Waste and Recycling Centres

WRWA currently provides a Household Waste and Recycling Centre (HWRC) at its Smugglers Way Transfer Station where local people can leave items for reuse or recycling or, if a reuse or recycling option is not available, for disposal. Residents wishing to deliver their Household Waste in a van have the option of delivering the waste to either Smugglers Way Transfer Station or Cringle Dock Transfer Station.

The Smugglers Way HWRC is based on a split-level concept, so that the public is physically separated from the operational activities. This layout provides greater flexibility to users when they deposit material and has reduced waiting times. This, combined with a significant increase in the number of cars able to queue on site at peak times, has helped to reduce local traffic congestion.

The design also allows for a wide range of best practice features including, amongst other things, bollard demarcation and real time queuing information to be displayed on the WRWA website. A webcam enables residents to view the HWRC entrance ramp so they can assess the situation regarding queuing before visiting the site. A vehicle number plate recognition system is also operational which is designed to detect cars that use the site too frequently and highlight this to the site advisors, who can monitor the types of waste being disposed of by the vehicle owners. This helps to prevent commercial waste operators using the site illegally. This system also records the vehicle details and has a database facility to enable Authority staff to monitor site usage.

Following the closure of the Cringle Dock HWRC in 2013 the Authority carried out a review of the operation of the Smugglers Way HWRC, particularly focussing on waste that is technically defined as industrial (such as tiles, windows, doors, timber and wooden flooring, bricks, rubble, paving, stones and hardcore, bathroom suites and fittings, fencing, sheds, kitchen units and fittings, soil, turf, etc). From April 2013 this waste continues to be accepted at the HWRC free of charge from residents using cars, motorcycles, bicycles or on foot.

However, free delivery of residents' waste in vans is limited to that which most people would reasonably take

Feathers Wharf

The Bulk Bays for receiving source-segregated recyclables were moved to Cringle Dock in 2013 and therefore the Authority does not currently require the use of its area of land at Feathers Wharf, adjacent to Smugglers Way Transfer Station, for waste disposal purposes. It has been agreed that for the foreseeable future the land will be leased to a third party and, in 2015, planning permission was granted by Wandsworth Council for a change of use to Storage of Construction Plant and a new tenant took up occupancy. However further plans for the future use of the site are discussed in Section 8.

Full information on WRWA's Household Waste and Recycling Centres can be found by following the link www.wrwa.gov.uk



The Household Waste and Recycling Centre at Smugglers Way



with them when moving house and which could not reasonably be delivered in a car, e.g. large items of free standing furniture and white goods.

An example of the layout of the site is shown below.

We have set up two large bays for specific items that are intended for recycling or reuse (see Bay A and Bay B below). HWRC staff are proactive in ensuring that residents reuse and recycle as much of their waste as possible and only use the general household waste containers as a last resort. We have individual containers for a whole range of items that can be recycled. These are shown below.

	paint
	carpet
	scrap metal
	garden waste
	small appliances
	cardboard
	wood & timber
	textiles
	hardcore & rubble
	clear sack mixed recycling

On 24th March 2020, following a statement from the Prime Minister on 23rd March, the Household Waste and Recycling Centres at Smugglers Way and Cringle Dock were

temporarily closed due to the Covid-19 outbreak. However Transfer Station and MRF operations were able to continue as normal.



BAY A RECYCLING AREA

Bay A is for the following items which are beyond repair, and will be recycled:

- Books (reused and recycled)
- Used engine oil
- Large appliances
- TVs and monitors
- Printer cartridges
- Fluorescent tubes
- Mobile phones
- Batteries
- Gas bottles
- Cooking oil
- Spectacles
- CDs and DVDs

BAY B REUSE AREA

Bay B is for the following items which are in reasonable condition. They will be repaired or reused:

- Large appliances
- Flat panel TVs
- Furniture
- Bicycles
- Sports equipment
- Bric-a-Brac

Please ensure items are in good cosmetic condition

Recovery

The journey by river

An integral part of WRWA's contract with Cory is the use of the River Thames for transporting its residual waste that cannot be reused or recycled. The waste is loaded by crane onto one of Cory's barges in sealed containers – each of Cory's 47 barges has a 300 tonne capacity and is pulled by a tug, which tows them some 20 miles downriver to the Riverside Resource Recovery Energy from Waste facility in Belvedere.

The river operation is governed by the tides. Craft containing full containers go downstream on the ebb tide and empty containers are taken back upstream on the flood tide.

Transporting waste by river is occasionally difficult, particularly when there are high winds or fog, but from an environmental point of view it is an excellent method of transport. The four hour journey from the transfer stations to Belvedere, negotiating bends, bridges and currents, requires an experienced skipper at the wheel. Although commercial river traffic has declined, the tugs' crews need to keep a watchful eye for pleasure craft and other users of the River.

Cory's fleet is headed up by its four tugs which have been in operation since 2010. The tugs Reclaim, Recovery, Redoubt and Resource are just the latest in a long line of Cory tugs that have been operating on the River Thames for over 110 years and in June 2012 they led the working boats section of the Queen's Jubilee Pageant.

Overall Cory transports around 680,000 tonnes of waste a year on the Thames, thus saving more than 100,000 heavy vehicle movements a year on the capital's already congested roads.



Left: An integral part of WRWA's contract with Cory is the use of the River Thames for transporting its residual waste.

Right: The Belvedere Energy from Waste facility is the largest in the UK and generates 72MW of power.

To complete the process, the Incinerator Bottom Ash (IBA) produced at the Riverside facility is taken back on Cory's barges in specially designed containers to an IBA processing facility at Tilbury Docks, developed by Ballast Phoenix. This can process 170,000 tonnes of IBA a year to recover metals and produce a construction aggregate currently being used on the M25 widening scheme and many other road and construction projects.

Belvedere Energy from Waste plant

The Belvedere Energy from Waste plant (EfW) plant is owned and operated by Riverside Resource Recovery Limited (RRRL), a wholly owned subsidiary of Cory. The Facility provides for the incineration of waste, and the use of the heat from the process to generate electricity through steam generation in boilers.

It is the second largest EfW Facility in the UK and one of the largest in Europe, which generates 80 MW of power (6MW of which is used on site and the remaining 74 MW is exported to the National Grid). The facility is consented to receive up to 785,000 tonnes of residual waste each year and RRRL became fully responsible for its operation in 2011.

Use of the EfW plant does not artificially limit WRWA's ability to reduce or recycle its waste. Whilst WRWA has the benefit of a guaranteed level of capacity at the facility it remains free to reduce or recycle its waste without limitation. WRWA is not required to supply any guaranteed level of tonnage to the facility, or make any minimum payment. Indeed, the Authority receives a royalty for any capacity it gives up and is therefore positively incentivised to make such reductions.



Overall Cory transports around **680,000 tonnes of waste a year** on the Thames, thus **saving more than 100,000 heavy vehicle movements** a year on the capital's already congested roads.

The planning permission only allows for 195,000 tonnes per annum to be delivered to the Facility by road, with all the remaining waste to be supplied by river. All but 115,000 tonnes of the river waste (transferred via the Port of Tilbury) must originate from within Greater London. The majority of the waste is therefore transferred to the facility via the Authority's Transfer Stations at Smugglers Way and Cringle Dock, the City of London's Transfer Station at Walbrook Wharf and the Transfer Station at Northumberland Wharf in Tower Hamlets.

The Incinerator Bottom Ash (IBA) is being processed at Ballast Phoenix Limited's IBA recycling plant at Tilbury Docks which was constructed to recycle the bottom ash produced at the Facility.

Over 150,000 tonnes per annum of the inputs to Belvedere (approximately 28%) will end up as bottom ash and this is transported from Belvedere by river barge to Tilbury. Ferrous and non-ferrous metals are reclaimed during processing, with the remaining material being processed into aggregate, destined primarily for new road schemes.

In October 2018, an undefined power disruption occurred at the Belvedere facility that resulted in damage to the turbine, which had to be shipped to Germany for repair, and during this period electricity could not be exported to the National Grid. The restored turbine was fully operational again by the end of May 2019.

The Riverside facility was officially opened by Her Royal Highness The Princess Royal in May 2012 and it is one of the UK's most efficient energy recovery plants and an important strategic waste management facility for the capital.

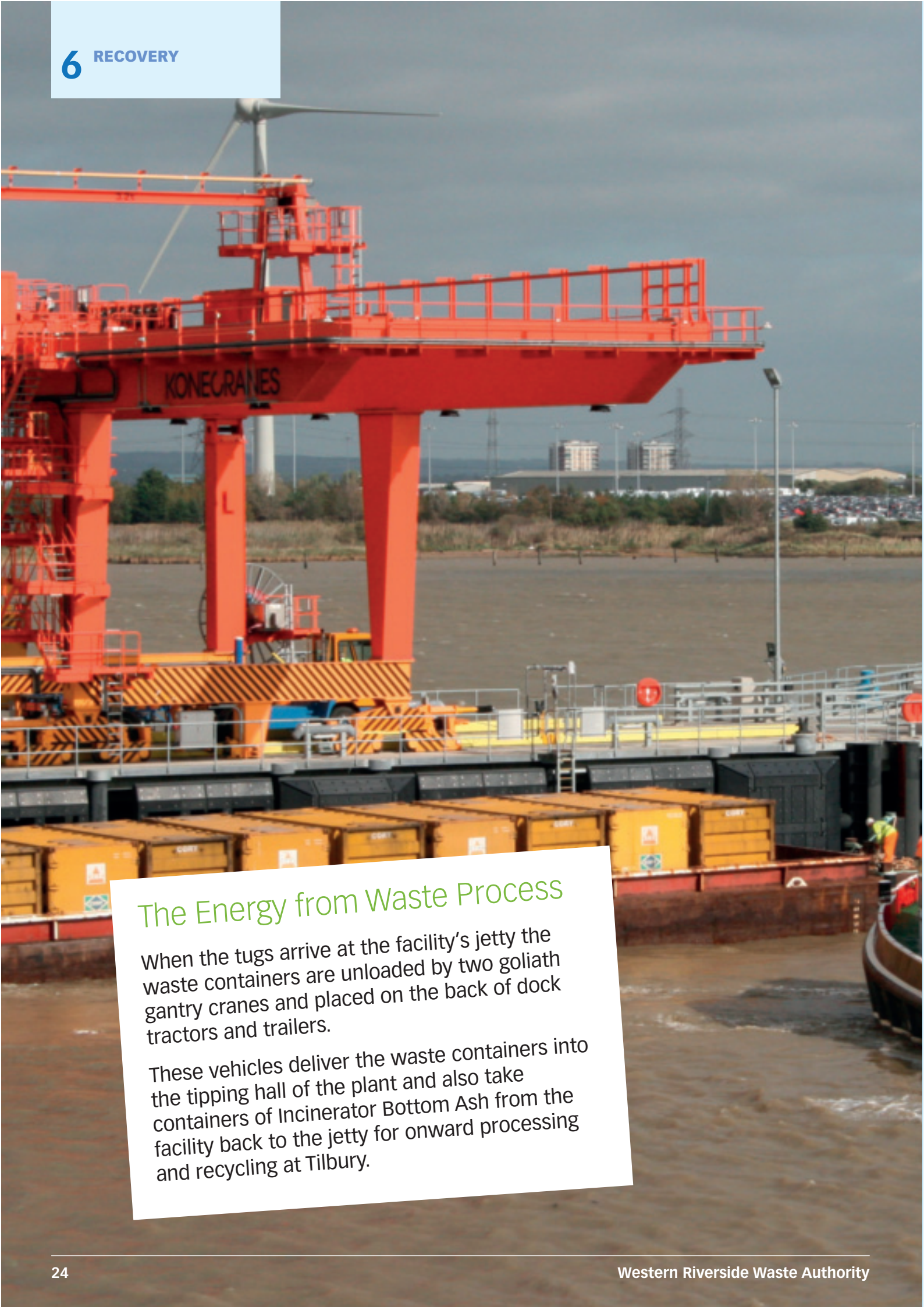

The Energy from Waste Process

When the tugs arrive at the facility's jetty the waste containers are unloaded by two goliath gantry cranes and placed on the back of dock tractors and trailers.

These vehicles deliver the waste containers into the tipping hall of the plant and also take containers of Incinerator Bottom Ash from the facility back to the jetty for onward processing and recycling at Tilbury.

The Energy from Waste Process

Tipping hall

1. Waste arrives in the tipping hall in containers on the back of RRRL's fleet of dock tractors and trailers and in a variety of waste collection vehicles from the surrounding area.

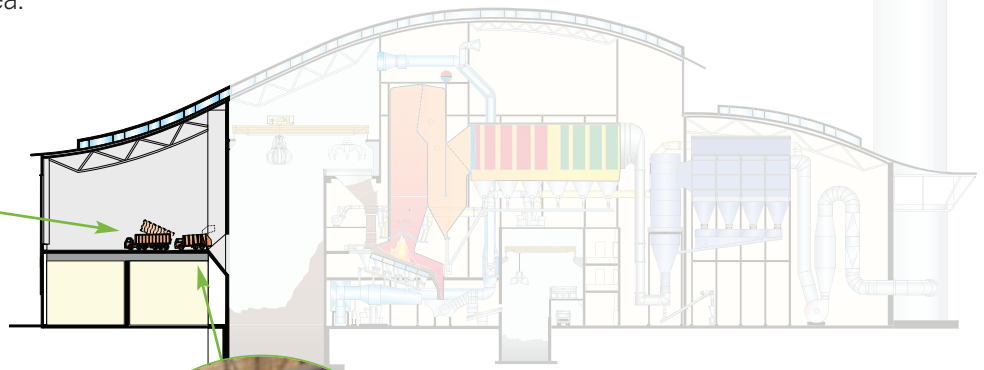

2. The waste is tipped into one of 12 tipping bays. Each bay has a hydraulically operated door which minimises noise and odour during the tipping operations. Lights on each tipping bay indicate to the drivers of the vehicles which bay is available to receive waste.



DID YOU KNOW?

The facility processes an average of 585,000 tonnes a year of waste over design life. Each container holds 12-14 tonnes of waste.

Waste bunker

1. The waste bunker is 30m deep, 61m long and 16m wide. It can hold up to around 10,000 tonnes of waste – enough to fuel the whole plant at full capacity for five days.

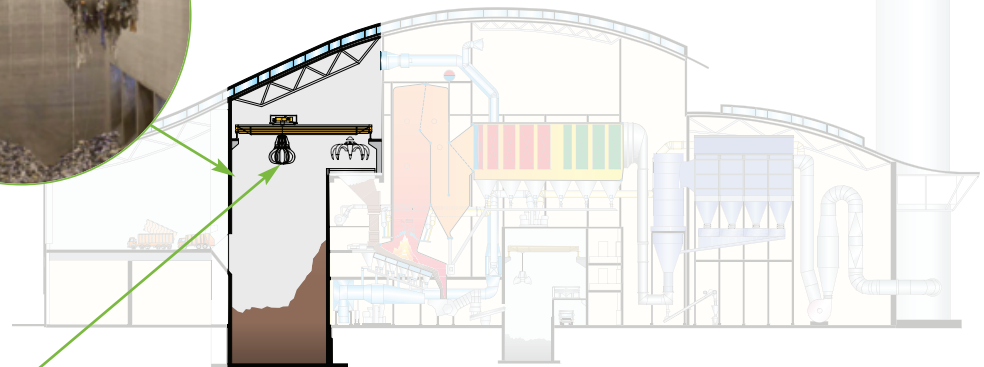
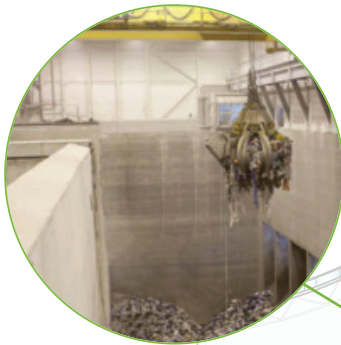

2. Overhead waste cranes mix the waste so it maintains a similar heating value throughout. The waste cranes feed each of the three combustion lines ensuring that each of the boilers has the required feedstock for continuous 24-hour operation.

DID YOU KNOW?

Infrared cameras detect any hot spots. If any hotspot exceeds 85°C water cannons will automatically operate.

Waste combustion

1. Waste is fed into one of the three feed hoppers by the overhead cranes. The waste then travels down the chutes and onto a horizontal feeder table.

2. Hydraulically operated ram feeders push the waste onto the sloping grate.



3. The sloping stoker grate consists of alternate rows of fixed and moving cast steel bars. Through the forward movement of these bars the waste tumbles slowly down the burning waste bed. The resulting burnt out product – Incinerator Bottom Ash – falls from the base of the grate into a quench bath.



4. Primary heated combustion air drawn from above the waste bunker is distributed into the waste bed through holes in each cast steel grate bar. This process dries the waste and provides the correct amount of air to allow good combustion of the waste bed. In compliance with the Waste Incineration Directive, the combustion process operates at <850°C.

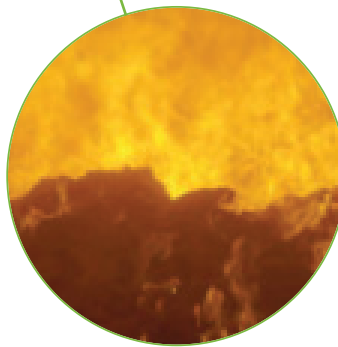

5. Secondary swirling air introduced above the grate through cylindrical nozzles ensures that the gases in the waste are thoroughly mixed. This results in a fully optimised combustion process and encourages low levels of toxicity in the gases leaving the combustion chamber. NOx levels are reduced by ammonia injection to the levels required in the Environmental Permit.

7. Gases and smoke produced during combustion are drawn through the gas passes of the boiler by an induced draught fan.



6. Heat from the flue gases heats the water in the boiler tubes turning the water into super heated steam. This steam drives the turbine which in turn drives the generator, producing electricity.

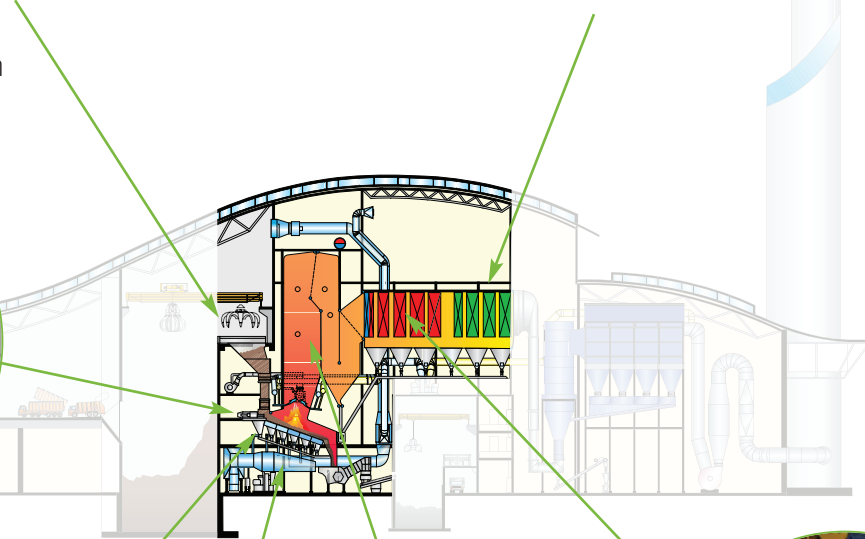

Incinerator Bottom Ash (IBA)

DID YOU KNOW?

Incinerator Bottom Ash is a by-product of the combustion process and accounts for approximately 28% of the facility's waste throughput.



1. The Incinerator Bottom Ash which drops from the grate into a quench bath is then pushed by hydraulic rams onto vibrating conveyors and from there falls into the ash bunker.

Any oversized metal or other objects fall off the conveyor into skips to be recycled.



2. The Incinerator Bottom Ash is moved by overhead ash cranes from the ash bunker into elevated loading hoppers which are positioned over an internal roadway.



3. Incinerator Bottom Ash is discharged from the hoppers into ash containers.

These containers are transported to the jetty on dock tractors and trailers and placed on barges to be taken to the IBA processing facility at Tilbury.

Around 170,000 tonnes of ash per year is sent for processing.

Flue gas treatment

1. Flue gases leave the boiler and pass into a Turbosorp® reactor tower where hydrated lime, powdered activated carbon and water are injected into the swirling gas flow. These help neutralise acids and capture heavy metal particles.

DID YOU KNOW?

The Air Pollution Control Residue (APCR) is a by-product of the combustion process and accounts for approximately 4% of the facility's waste throughput.

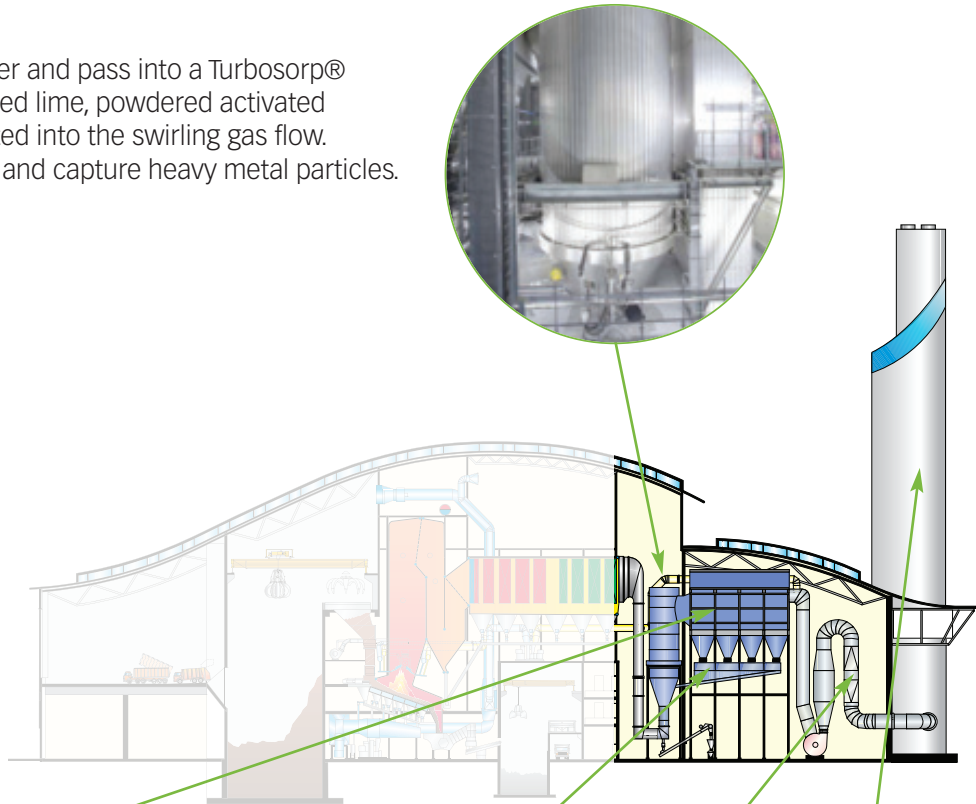

2. Gases from the Turbosorp® reactor tower are drawn into one of three fabric bag filters which each consist of 2,048 6m long cylindrical fibre bags on steel wire cages. The clean gases pass through the filters and the Air Pollution Control Residue (APCR) collects on the outer surface of the bags.



3. Compressed air pulses shake off the APCR into silos. The APCR is removed from the site by road tanker.



4. Clean hot gas is drawn out of the fabric filter bags through a heat exchanger which allows heat to be transferred from the gas into the boiler feed water.



5. An induced draught fan for each of the three lines draws clean cooled gas up the 85 metre stack where it is discharged into the atmosphere. Emissions equipment continually monitors plant performance in relation to the environmental permit.

Steam turbine and generator

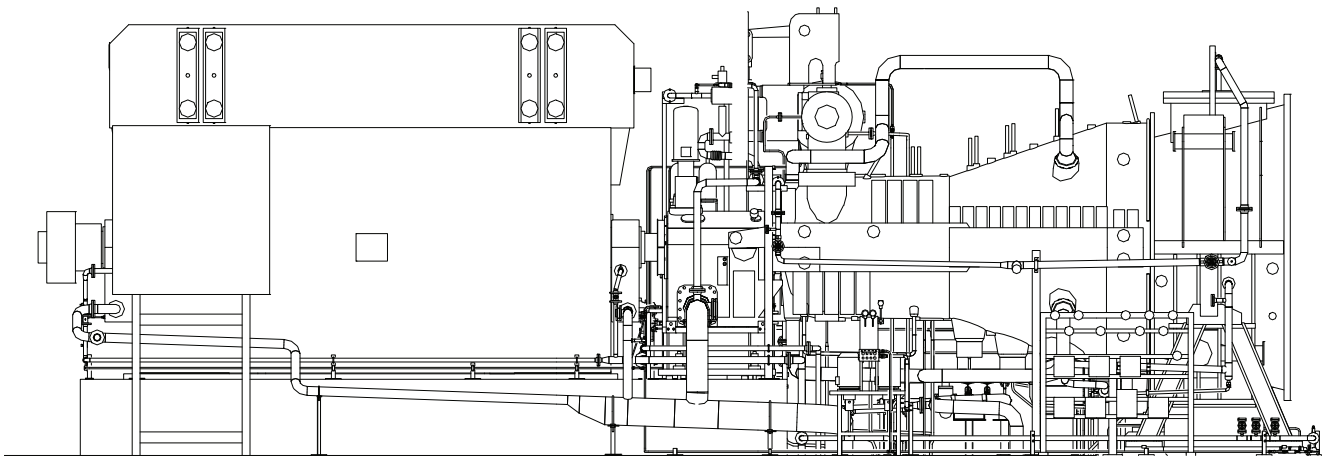

1. High pressure steam from each of the three boiler drums is directed onto rings of fixed blades causing the turbine to rotate at high speed.



2. The steam turbine is coupled to the electric generator which rotates at the same speed as the turbine. This produces high voltage electricity which is sent to the 132kv substation and on to the National Grid. The plant produces enough electricity to power around 100,000 homes.



3. Exhaust steam leaves the turbine and is cooled in an air cooled condenser. The resulting condensate is then returned to the boilers as boiler feed water.

Looking back – 2014/15 to 2019/20 review

Waste trends

For WRWA, the real success generally in the last decade has been the significant decrease in total waste arisings which was accompanied to begin with by a simultaneous increase in recycling tonnages. Since 2012/13 we have met and achieved our aim of reducing to “zero” the waste sent direct to landfill. However, in the six year period under review, the total waste managed by the Authority has fallen and indeed over the last decade the Authority and its Constituent Councils have been successful in achieving the aims of the waste hierarchy by reducing the Municipal and Household waste it handles against a background of increasing population and household numbers. The Authority’s recycling tonnage consists of mainly dry, post-consumer recyclable material with very limited amounts of green garden waste – the Authority’s area being among the most urbanised in the country.

The delivered tonnage of recycling has remained relatively constant in the last three years, although it is worth noting that wood is not counted as part of the recycling tonnage as it is processed via Biomass which is a recovery process.

The reduction in general waste tonnage in 2019/20 is likely to be due to a number of factors, including light weighting by manufacturers and the initial impact of the Covid-19 outbreak and closure of the Household Waste and Recycling Centre.

Performance monitoring

WRWA continually monitors its performance. Waste tonnage data is collated daily, weekly, monthly, quarterly and annually and is analysed to establish trends for each type of recycling or waste received. Budgets are similarly monitored and regular financial reports are presented to Members three times per year.

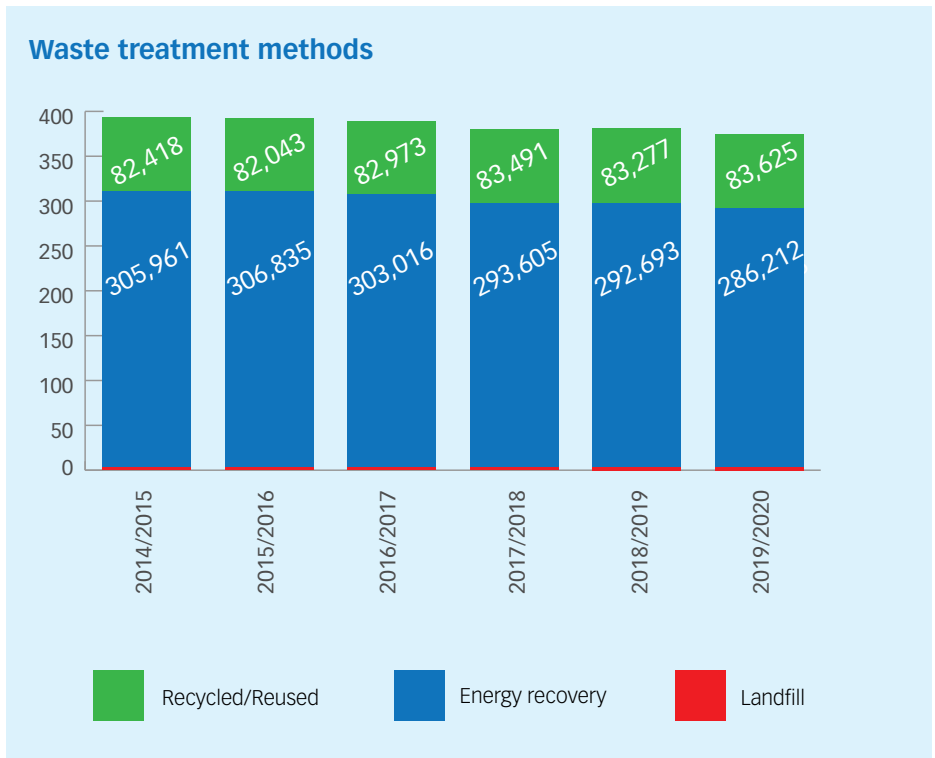

WRWA officers hold periodic meetings with officers from the constituent councils and in 2009 the constituent councils agreed that WRWA could charge them directly on the type and tonnage of material that they

individually delivered to it. This means that the cost of waste treatment is borne by the councils fully in accordance with the “polluter pays” principle and it also means that they too are directly and continually monitoring WRWA’s performance.



Looking forward – a future for waste

Our plans for the future

Cringle Dock

Cringle Dock is one of the fifty Safeguarded Wharves located on the River Thames allocated for the handling of cargo by barge. It is one of London's key waste infrastructure sites and now transfers around 260,000 tonnes a year, or 5,000 tonnes each week, of non-recyclable 'black bag' waste – an amount equivalent to one quarter of that produced in the whole of Wales – which demonstrates Cringle Dock's importance as a strategic public asset.

Cringle Dock has operated as a waste transfer station since 1972 and is protected by planning policies contained in the London Plan 2011 and Wandsworth Council's Core Strategy. These policies require that any development adjacent to a Safeguarded Wharf must minimise the potential for conflicts of use and disturbance.

In the last decade planning decisions have released industrial sites, such as Battersea Power Station in the Nine Elms Vauxhall area of London where Cringle Dock is situated, to be

redeveloped for mixed residential, commercial, retail and leisure complex uses. The existing waste transfer station at Cringle Dock does not sit comfortably with the new surrounding land uses. The transfer station is over 40 years old and architecturally very much out of keeping with the proposed new developments. Furthermore, the current operational design of the waste transfer station is based around waste storage bunkers; whilst functional, the open air system can, on occasion, emit odour nuisances.

Despite its Safeguarded Wharf status, without redevelopment, the arrival of a large numbers of residents, workers and visitors to the area will undoubtedly cause issues that could seriously impinge on the operations at Cringle Dock.

Since 2012, the Authority has been in discussions with the owners of Battersea Power Station to see what could be done to safeguard the long-term operation of Cringle Dock, by improving it operationally and visually and thereby reducing the potential for conflict with its new neighbours and contributing towards the strategic regeneration of the area generally.

There is now a shared goal to provide a state-of-the-art waste processing

facility that minimises, or even removes, the need for it to interact with or impact upon its new neighbours in any way. Noise, dust, vibration, smell and even visual impacts can and have been removed through design.

In 2016, planning permission was granted by Wandsworth Council's Planning Committee for a proposed new facility at Cringle Dock based on a design incorporating residential accommodation facing the Thames above a new Waste Transfer Station (WTS). The new WTS would use modern equipment and processes to continue operations with much greater control over environmental issues. The new WTS design is both safer and operationally very much more resilient than the current operation. Further planning approval was granted in 2017 to amend the existing permission for the area currently set aside for the Bulk Bays to be used to provide around 4,700sq m of additional commercial floor space.

In order to help facilitate the development project the Safeguarded Wharf status of the Bulk Bay area at Cringle Dock was successfully transferred to Smugglers Way by the Secretary of State for Communities and Local Government in December 2017.

Feathers Wharf

WRWA currently operates a Bulk Waste Transfer Station (BWTS) at Cringle Dock which receives and bulks up green waste and recyclables. The facility comprises a combination of open bays and an ageing temporary transfer building. The materials brought to the BWTS are generated by the public delivering bulky waste and recyclables to the Household Waste Recycling Centre at Smugglers Way and by local businesses.

However, as a result of the proposed redevelopment of Cringle Dock detailed above, plans for the relocation of the BWTS have now been developed. These proposals involve replacing the Cringle Dock facility with a new modern BWTS at Feathers Wharf, Smugglers Way. This will assist in the logistics of any upgrade or redevelopment of Cringle Dock, by vacating land that could accommodate a temporary waste transfer facility to allow uninterrupted operation of the facility during any works to the existing wharf.

Much of the material currently managed at the Cringle Dock BWTS originates from the Smugglers Way facilities. Moving the facility to Feathers Wharf, Smugglers Way, will remove another 2,200 HGV vehicles journeys each year from London's roads. The scheme makes beneficial use of an operational site at Feathers Wharf and provides for effective integration of related operations which have previously been carried out on different sites. The proposed operation will therefore complement the existing waste management functions at the Smugglers Way site, with beneficial utilisation of existing site access and on-site infrastructure (weighbridges, internal roads and traffic control system).

In 2015 a planning application was submitted to Wandsworth Council's Planning Committee to construct a new Bulk Waste Transfer station, to handle up to 25,000 tonnes of recyclable materials on the southern part of the Feathers Wharf site, and in

2017 a further planning application was approved to extend the period of use until December 2032.

The proposals provide a comprehensive scheme which combines the proposed BWTS with a current temporary permission for plant storage, with each having an independent access and haul road. The whole Feathers Wharf site will be upgraded by providing a new, good quality BWTS building, together with substantial new landscaping and biodiversity measures, as well as a new public riverside walkway.

The proposed walkway is an exciting scheme to open up the river easement zone along the River Wandle and the River Thames as a public walkway. This also involves a significant refurbishment of the existing unused high level walkway which runs along the northern side of the existing Smugglers Way facility. This will connect up the existing riverside walkways to the east and west which will allow the public to walk along the riverside.

Waste Management Strategy Review

WRWA's original Waste Management Policy was established within the framework of the Joint Municipal Waste Management Strategy which was agreed in 2006. However after a number of years it became apparent that the Policy should be reviewed and a new joint high level Waste Policy document to guide future service provision and to clearly demonstrate continued partnership working was drafted, with the assistance of the four boroughs, and agreed in 2013. This document sets out the agreed waste policy and defines the parameters within which waste will be managed within the Authority's area in a manner that will:

- embrace the concepts of waste prevention;
- seek to achieve a continued reduction in the amount of waste produced;

- increase the amount of waste that is re-used;
- recycle, compost or recover energy from the waste that is collected;
- minimise the environmental impact of transporting the waste;
- encourage the creation of new, meaningful, job opportunities;
- minimise disruption to others; and
- reduce costs of operations to provide the best possible deal for Council Tax payers.

The full Waste Management Policy document can be found on the Authority's website. Future European, National and Regional waste priorities and strategies are currently at various stages of development and consultation and the Mayor of London published his London Environment Strategy, proposing new waste recycling targets, in May 2018.

In 2017 the Authority considered its own Recycling Performance report and also held a seminar for Authority Members, followed by a further meeting with officers from the constituent councils, where a number of new proposed waste prevention initiatives and interventions were discussed. Further consultations also took place with other London Waste Disposal Authorities and sustainability experts. The main conclusion drawn from these meetings is that Waste Prevention will need to form part of a longer term Waste Prevention Plan and that this would form part of a new Joint Waste Management Policy between the Authority and the constituent councils

In September 2018 it was agreed to delay the production of the document until after the Government has published its Resource & Waste Strategy, the introduction of the EU Circular Economy Package, Brexit impacts and the potential introduction of a Deposit Return Scheme. It is now likely that the draft policy document will be presented to the Authority in 2020.

Sustainability statement

Through its Waste Management Policy and the letting of its Waste Management Services Agreement with Cory Riverside Energy the Authority has been able to significantly increase the proportion of waste from within its area that is reused and recycled and all of its residual waste is now used to recover energy at the Belvedere EfW Facility, rather than going to landfill.

Following the Government's waste hierarchy will generally lead to the most beneficial outcomes in terms of climate change and the overall reduction in the waste handled by WRWA (as shown in the graph in Section 7) has delivered the greatest savings both environmentally and financially.

Transporting the residual waste along the River Thames by barge saves London's congested roads from 100,000 heavy goods vehicle journeys a year.

The residue from the Energy from Waste facility's burning process is, again, transported by barge from Belvedere to Tilbury to be processed



into aggregate for the construction industry.

The Authority will, through its future policies continue to endeavour to further reduce the environmental impact of its waste management activities.

The residue from the EfW facility's burning process is transported by barge from Belvedere to Tilbury to be processed.



Financial statement

WRWA's responsibilities

The Authority is required to ensure that its business is conducted in accordance with the law and proper standards, and that public money is safeguarded and properly accounted for, and used economically, efficiently and effectively.

It also has a duty under the Local Government Act 1999 to make arrangements to secure continuous improvements in the way in which its functions are exercised, having regard to a combination of economy, efficiency and effectiveness.

A brief summary of the draft unaudited Financial Statements for 2019/20 is shown opposite.

Auditors' report

Deloitte LLP, the Authority's external auditor, published its annual audit letter for the financial year 2018/19 in March 2020, in which it confirmed that it had:

- audited the Authority's accounts in line with the Local Audit & Accountability Act 2014 and the Code of Audit Practice and issued an unqualified audit report on 5th March 2020;
- reviewed the Authority's Annual Governance Statement and found no areas of concern to report; and
- issued an unqualified value for money conclusion on 5th March 2020 in respect of the arrangements that the Authority has in place for securing financial resilience and also for securing economy, efficiency and effectiveness in its use of resources.

Summary of audited financial statements

Balance sheet as at 31 March 2020

	£000
Buildings and land owned by WRWA	58,907
Money owed to WRWA	19,296
Money owed by WRWA	- 9,659
Long term loans	- 3,000
Pensions liability	- 2,827
Total	62,717
Financed by:	
Accounting reserves	47,168
General Fund balances	15,549
Total	62,717

Operating costs and income (£000)

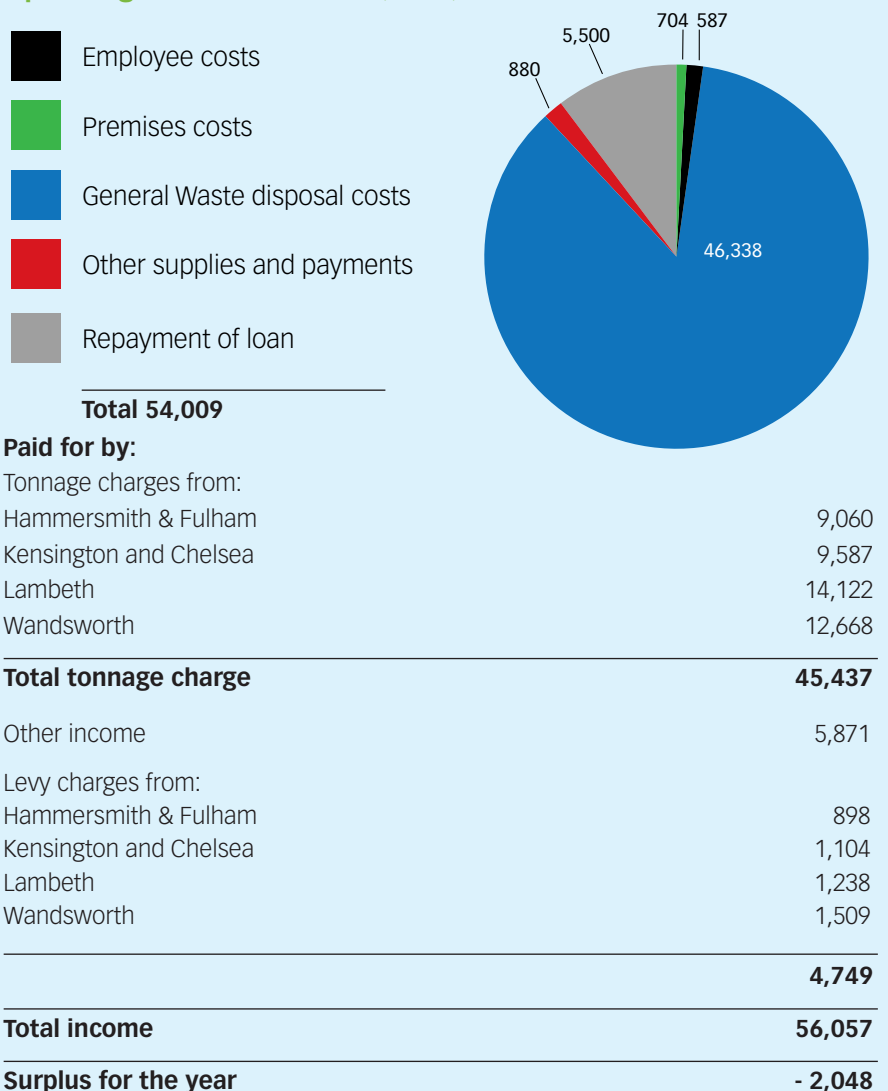

How can the public help?

Below are some tips that everyone can use to recycle more effectively.

1. Follow the Recycling guide opposite, or visit our website at www.wrwa.gov.uk to find out what can and cannot be recycled.
2. Also check out the website to find out why we can't recycle other materials in the recycling sacks and banks – including lids and shredded paper.
3. Limit the packaging you use – try to avoid using plastic bags if possible.
4. Wash out containers to avoid attracting animals, particularly if you store your recyclables outside.
5. Take responsibility, we can all make a difference.

Remember that up to 60% of the rubbish that ends up in the dustbin could be reused or recycled. However you should not use your recycling sacks and banks for disposing of normal rubbish, as currently around 15% of the material we receive is on the ❌ list which contaminates the rest.

6. Use your Household Waste and Recycling Centres. Although some of the material on the ❌ list cannot be recycled through the recycling sack and bank scheme, it may be possible to recycle it by taking it directly to your HWRC.

Recycling Guide

What can I recycle in my clear sack or recycling bin?

It couldn't be easier. Instead of throwing the items listed below into your general rubbish, just throw them into your clear sack or recycling bin.

The items just need to be clean and dry, and if you're putting in bottles or jars please remove the lids first.

Remember to recycle correctly by looking out for the materials below. Please do not put them into your clear sack or recycling bin.

	Paper, card & cardboard
	Glass bottles & jars
	Metal tins & cans
	Plastic bottles, pots, tubs & trays
	Cartons & Tetra Pak®

	Food waste		Nappies
	Shredded paper		Wood
	Metal		Clothing & textiles
	Polystyrene		Electricals & cables
	DIY material		Foil

Glossary

Co-mingled recyclable material

Mixed recyclable material that, in the WRWA area, is usually collected from the kerbside in a single clear sack, green bin or communal bin. The Authority currently limits these materials to glass bottles and jars, clean paper and card, food and drinks cans, Tetra Paks and plastic bottles.

Commercial waste (sometimes also referred to as Business or Trade waste)

Waste from premises used wholly or mainly for the purposes of a trade or business or for the purpose of sport, recreation, education or entertainment, but not including household, agricultural or industrial waste.

Detritus Waste

Is waste, generally from street sweeping or gully emptying operations, that requires some de-watering prior to its further treatment or disposal.

EfW – Energy from Waste

EfW facilities produce clean, renewable energy through the combustion of municipal solid waste in specially designed power plants equipped with the most modern pollution control equipment to ensure clean emissions.

Environment Agency (EA)

An agency established by statute to monitor and protect the environment. Its responsibilities include licensing of waste facilities and monitoring the Landfill Allowance Trading Scheme.

MRF (Materials Recycling Facility)

Is a facility to sort mixed delivered recyclables into individual commodities with a view to securing maximum recycling and value. The Authority uses a "clean" MRF to sort co-mingled recyclable materials into individual material types. A "dirty" MRF sorts recyclable material from the general waste stream.

Municipal Waste

This term is generally meant to refer to all waste that is in the possession or under the control of a waste disposal or waste collection authority. Sometimes also referred to as Municipal Solid Waste.

Recyclable materials

Recyclable materials are materials that are capable of being recycled. Dry recyclable materials include paper, plastic, glass and cans which are either collected separately or mixed, or are deposited into on-street banks by the public.

Recycle Western Riverside (RWR)

Is an outreach campaign which encourages residents to Reduce, Reuse and Recycle their rubbish (the three R's). The campaign has been running since 2002 and is funded by WRWA.

Waste Collection Authority (WCA)

The local authority (in London, the London Borough) responsible for collecting waste from households and certain commercial premises.

Waste Disposal Authority (WDA)

The local authority responsible for disposing of waste collected by the WCA. In London this can be either a joint waste disposal authority (e.g. WRWA) or a unitary authority. London Boroughs which are not a constituent member of a joint authority are both unitary disposal authorities and collection authorities.

Waste hierarchy

This is the Government's strategic order of preference for waste management under which, for instance, energy recovery and recycling is considered better than landfill. (This is described in more detail in Sections 2 and 3).

WEEE (Waste Electrical and Electronic Equipment Directive (2002/96/EC))

The Directive aims to reduce the waste arising from electrical and electronic equipment, and improve the environmental performance of all those components involved in the life cycle of electrical and electronic products.

WMSA – Waste Management Services Agreement

The Authority's long-term contract with Cory Environmental Ltd.





More information about recycling and waste management in your area can be found on our website www.wrwa.gov.uk or in your local newsletter and/or newspaper. These are listed below.

London Borough of Hammersmith & Fulham
Please visit www.lbhf.gov.uk for more information.

The Hammersmith & Fulham Chronicle or Our Patch also occasionally feature relevant information

Royal Borough of Kensington and Chelsea
Please visit www.rbkc.gov.uk for more information. The Royal Borough Newspaper also occasionally features relevant information

London Borough of Lambeth
Please visit www.lambeth.gov.uk for more information. Lambeth Talk also occasionally features relevant information

London Borough of Wandsworth
Please visit www.wandsworth.gov.uk for more information. Brightside also occasionally features relevant information.