

Reduce, reuse, recycle

Reuse — at home - KS2

It Might Be Useful

We need to change our throwaway culture.

We need your help to do it.

Think again – it might be useful!

There are lots of ways to reuse things yourselves without throwing them away. Things that you can do, and encourage other people to do.

Here are some ‘disposable’—throwaway items. Draw or write down some ideas of what you could use instead:



Reduce, reuse, recycle

Did you come up with lots of ideas?

A lot of disposable stuff is made of single use plastic (things that we usually buy, use once and then throw away) but there are often reusable things to use instead.

9 TIPS FOR LIVING WITH LESS PLASTIC

- 

1 Bring your own shopping bag
- 

2 Carry a reusable water bottle
- 

3 Bring your own cup
- 

4 Pack your lunch in reusable containers
- 

5 Say no to disposable straws & cutlery
- 

6 Skip the plastic produce bags
- 

7 Slow down and dine in
- 

8 Store leftovers in glass jars
- 

9 Share these tips with your friends

LESS PLASTIC.



WWW.LESSPLASTIC.CO.UK



You can also save money if you buy reusable items. They might be more expensive when you first buy them but over a year you will be saving money. E.g.

Reduce, reuse, recycle

DAY 1





OR

You could spend 60p on a bottle of water

You could spend £3 on buying a bottle to refill



DAY 365



OR

If you bought 1 bottle a week how much would you have spent?
£ _____

Or 1 bottle a day - how much would you have spent?
£ _____

Or if you are really good at maths - if you bought 1 bottle a day, at weekends only - how much would you have spent?
£ _____

OR

How much have you spent on refilling this bottle with tap water?
£ _____

How much have you saved on refilling this bottle?
£ _____

By using something and throwing it away you are also wasting resources (if you don't know what this word means, can you find out?). All materials have to come from somewhere on earth. Recycling, if you can, is better than putting it in the Rubbish bin but it still uses up resources to collect and recycle. **Reducing** by **reusing** is far better for the earth's resources.

And it's not just plastics we waste ...

Reduce, reuse, recycle

In this country, EVERY YEAR, we throw away...



22



300,000 tonnes of clothes



28 million toys



11,000 bicycles

It all adds up to a huge waste.

If you throw it in the Rubbish bin it will end up at the Energy From Waste plant where it will get burnt. What a waste. Think what you could do with it instead?

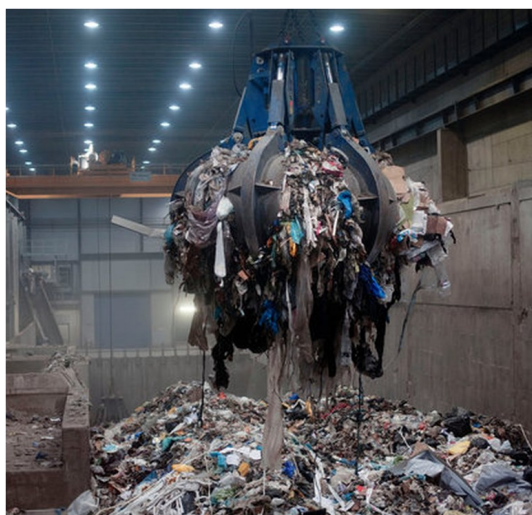

It is much better to Reduce the amount we use so there is less to throw away.

Reduce, reuse, recycle

Here are just some ideas of what to do with them instead. Can you think of any other ways to reuse?

Some charity shops are starting to do collections during lockdown when they are allowed.



Revamp old furniture.



Turn old clothes into something else like this t shirt bag.



Repair your bike if you have one. Lockdown is a good time to learn how to do this.



Swap or share toys with your siblings. After lockdown think about giving them to a charity shop. Remember if they go in the bin they end up being burnt. What a waste.

Reduce, reuse, recycle

On the next page is our Might Be Useful sing-a-long song—why not make a Reuse shaker to shake along to our song. Find clean items from your recycling and old bits of fabric.

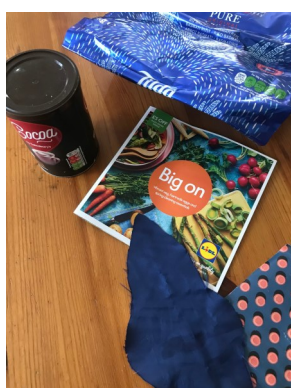

Any old container with a lid will do, even a box or yoghurt pot. I also found a free catalogue which had been put through my door (make sure your adults say it's ok to use), wrapping paper and fabric, even an empty shiny rice bag.

I used some milk bottle lids to fill it up to make the noise.

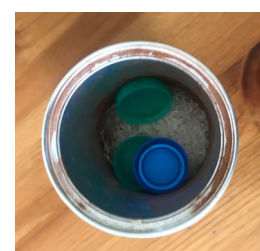

I haven't got any glue so I found some rubber bands. Get creative in what you can use if you haven't got glue or sticky tape or rubber bands! Just make sure the lid is secure so it doesn't all fly out when you shake along.

Can you think of any other instruments you can make from reusing stuff you already have or from recycling? Here are some of my favourites I've found:



Reduce, reuse, recycle

This is sung to the tune of **Glory, Glory, Hallelujah.**

This is sung to the tune of **Glory, Glory, Hallelujah.**

You could ask an adult how it goes or make up your own tune. Don't

'Might Be Useful' song

When you've finished with your stuff don't just throw it in the bin!

When you've finished with your stuff don't just throw it in the bin!

When you've finished with your stuff don't just throw it in the bin!

What else can you do?

Think again! It might be use--ful!

Think again! It might be use--ful!

Think again! It might be use--ful!

Useful for me or you.



Why not think of some different words that could be used for another verse?

Think about some of the stuff you use and throw away and what you could do with it instead?

There are some ideas on the next page if you want help to think of some things.

Reduce, reuse, recycle

Can you see what they used from recycling to make them?



Reduce, reuse, recycle

Be smart play your part—cut out and colour in these pledges (promises).

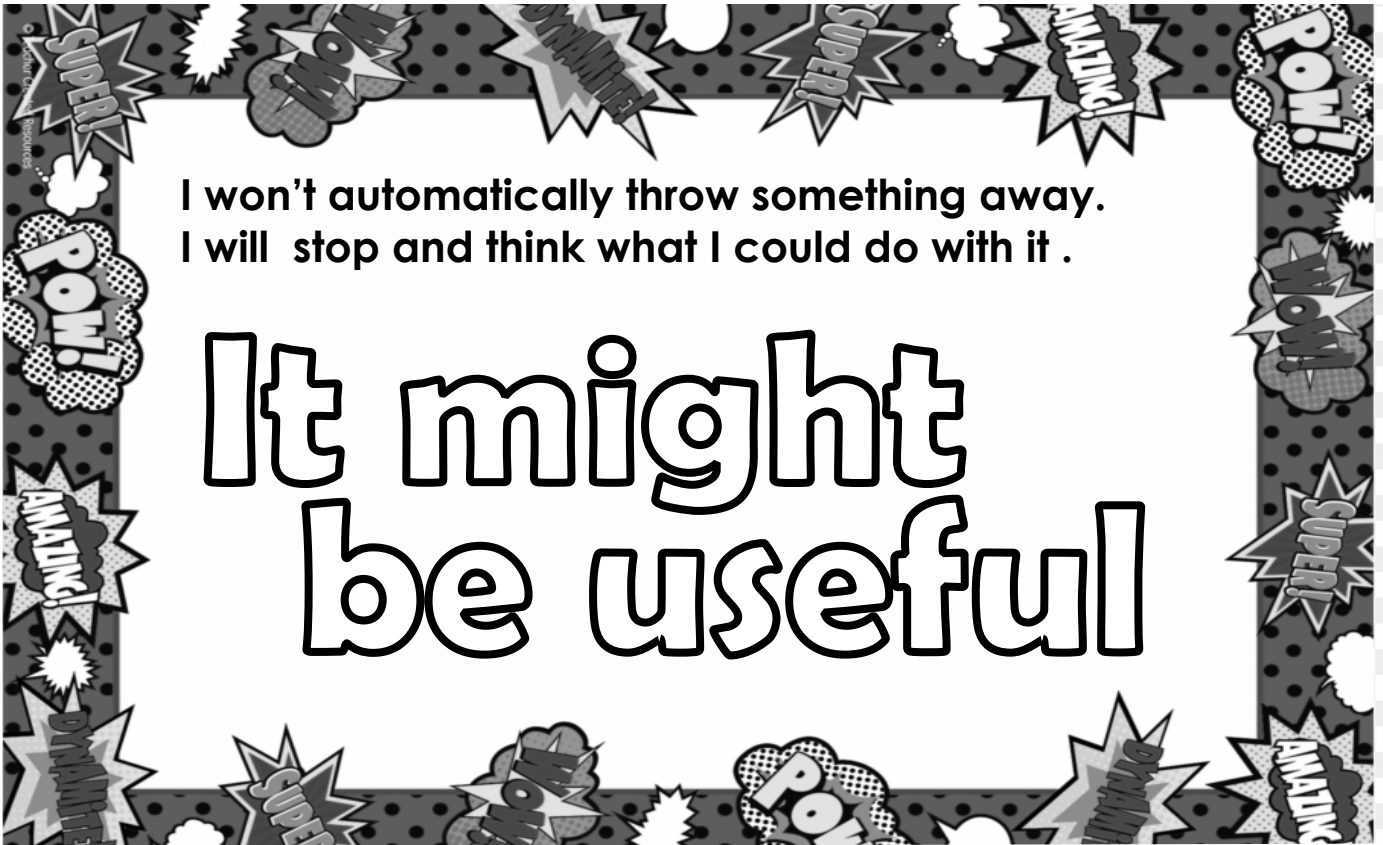
The top pledge card is framed by a decorative border with a comic book aesthetic. It features various starburst and cloud shapes containing the words 'SUPER!' and 'AMAZING!' in bold, stylized fonts. The background of the border is a dark grey with white polka dots.

I won't automatically throw something away.
I will stop and think what I could do with it .

It might be useful

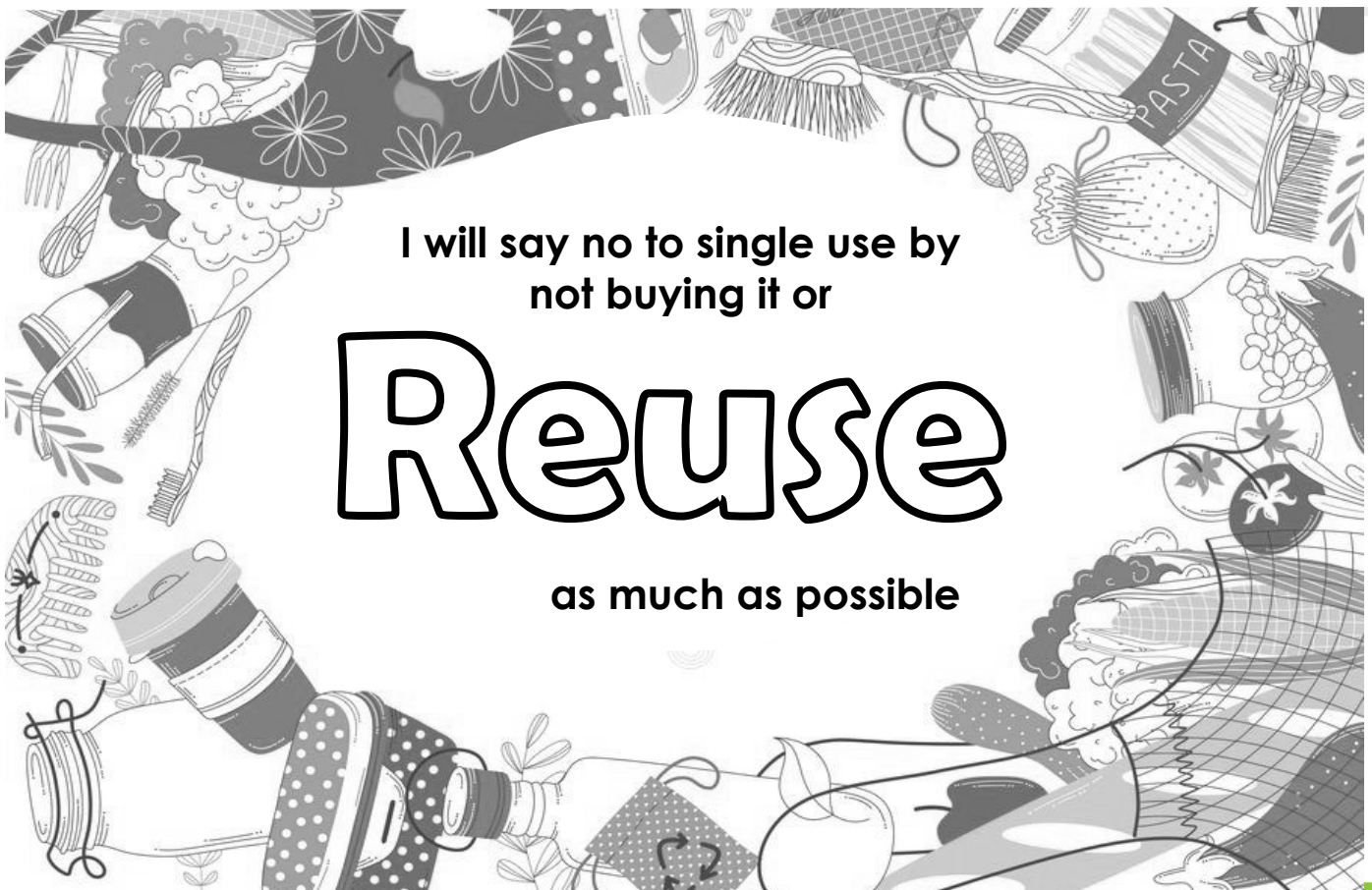
The bottom pledge card is framed by a decorative border featuring various household and kitchen items. The items include a toothbrush, a hairbrush, a pasta box, a coffee cup, a water bottle, a glass, and a recycling symbol. The background of the border is white with grey and black line art.

I will say no to single use by
not buying it or

Reuse

as much as possible

Reduce, reuse, recycle

Make a Tetrapak juice carton wallet



Ask an adult for any help cutting or using scissors/butter knife.

Templates are on the next 2 pages.

These are for a 1 litre carton and one where the top is not flat!



INSTRUCTIONS:

1. Carefully open out the carton where it is glued at one edge and flatten out the whole thing.
2. Tape and trace the template on the blank side of the carton, lining up the carton lines with the template. Make sure to also line up the spout hole. Trace the dotted lines, a biro is good, and press hard so you can see an indent in the carton where the lines are. Cut out the shape from the carton.
3. Using scissors cut out the lower hole. Score all the dotted lines—you could also use a butter knife. Use a ruler to get the lines straight.
4. Following the dotted fold lines you created in the semi circles, make accordion type folds i.e. one way and then the other, each side.
5. Tightly squeeze the accordion folds. Fold the top down pushing the spout through the hole. Screw on the lid to keep wallet closed and hey presto!

Further instructions with pictures are here:

<https://www.instructables.com/id/Milk-carton-wallet-1/>

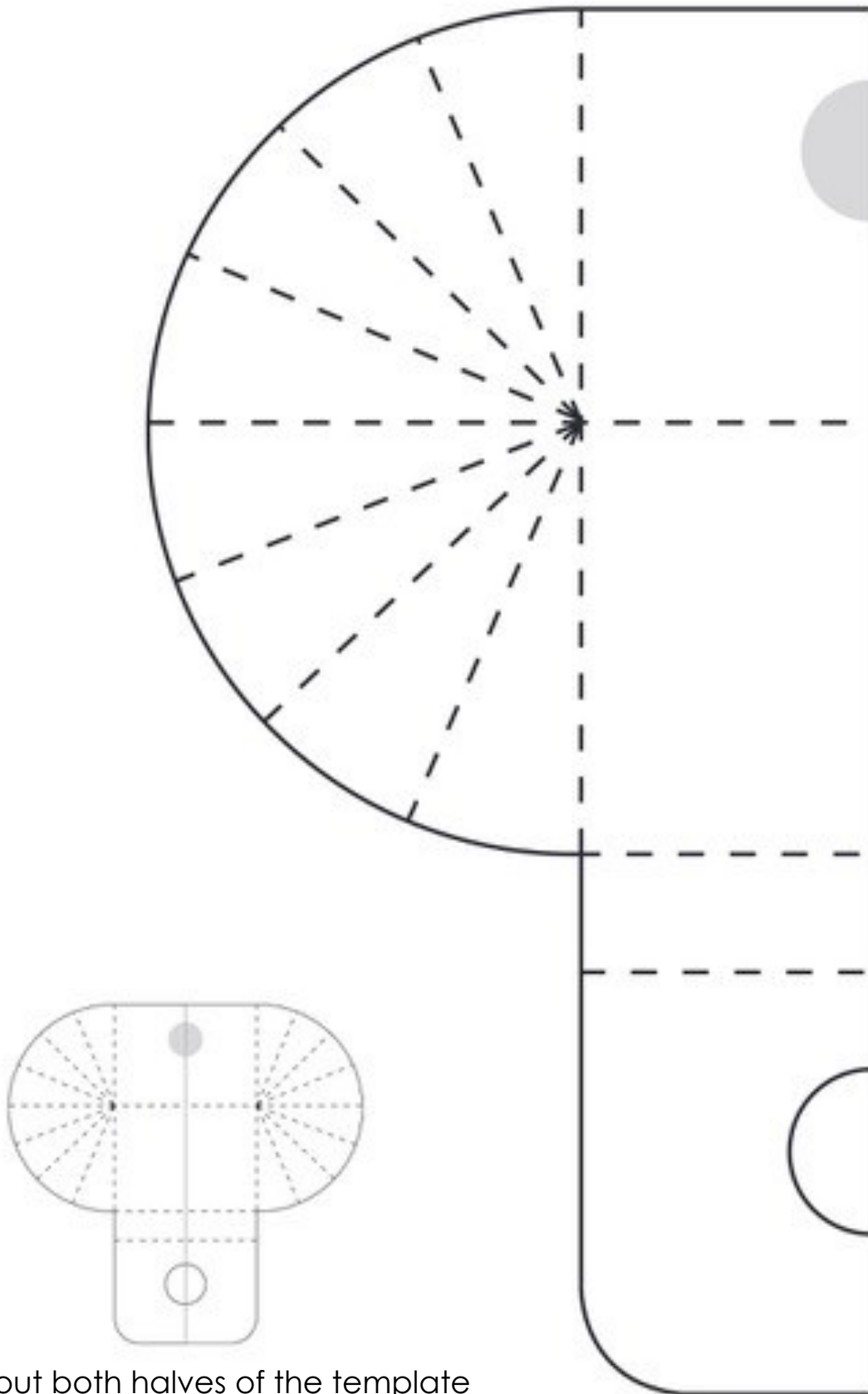

Cut out both halves of the template and tape them together down the centre line.

